

# MS Ultrasonic Sieving System 60 US

**Efficiency and Reliability in Powder Coating Technology**

POWDER HANDLING

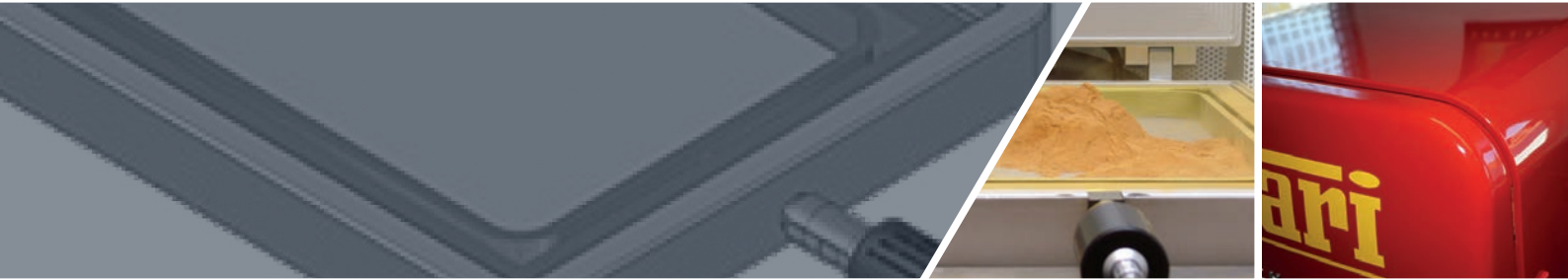

Clumps and impurities within fresh and re-cycled powder can cause an uneven finish as well as blockages in the supply line. To ensure that powder coating material reaches the spray booth free of clumps and impurities MS has developed the Ultrasonic Sieving System 60 US.

Using the MS ultrasonic sieve can improve finish surface quality by breaking down clumps and filtering out impurities, whilst at the same time significantly reducing the waste powder ratio.

The ultrasonic controller will monitor the volume and consistency of the material and set the oscillation frequency to the most efficient and effective level for the job. This ensures that even the finest foreign particles are filtered out from the fresh or recovered powder, improving finish and dramatically reducing rejection rates.

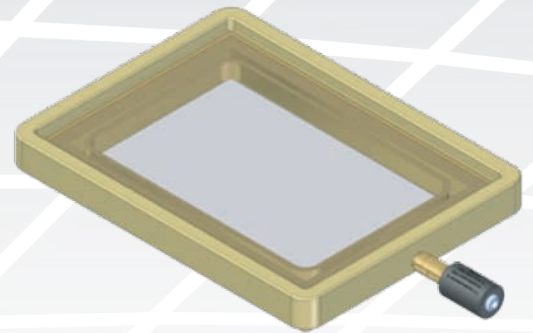

***High sieve capacity up to 6 kg/min with mesh widths between 100 - 200µ***

***MS Ultrasonic Controller provides***

***Fully automated frequency Intensity variation can be adjusted for various powder grades through 999 customizable process programs***

***Can be integrated and retro-fitted into any powder recovery system***

***Location-independent, can be used in powder kitchen, fluid container or powder warehouse***

***Easy-clean design for quick color changes***

***Cost savings through efficient processing of re-cycled powder***

The Controller unit can be linked to PLC and other control systems through its standard digital and analogue connections and its modular design means that it can be installed independently from other powder system units or fully integrated into the Powder Kitchen. The controller provides 3 standard system programs: Continual, Pulse or Amplitude Sweep and has the memory storage capacity for 999 process programs.

The easy-clean sieve system can be installed and retro-fitted in any powder coating system but works particularly well with MS Powder Kitchen and Finishing Systems.



MS Ultrasonic fluid container 90 L

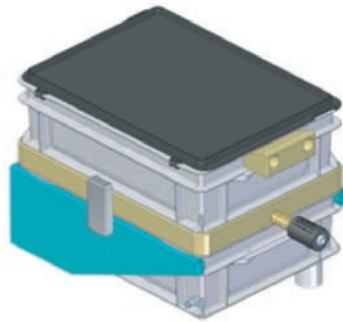

MS Ultrasonic sieve unit with wall bracket



MS Ultrasonic powder sieve unit 30L for warehouse sieving

