

**BINKS<sup>®</sup>**

**Instruction Manual**  
**Active Surge Eliminator**  
**104050 – X – X**

<b>Product Description</b>	Surge chamber/eliminator -104050, 104052, 104053, 108120,
<b>This Product is designed for use with:</b>	Solvent and Water based Materials
<b>Suitable for use in hazardous area:</b>	Zone 1 & 2
<b>Protection Level:</b>	II 2 G X IIB T4
<b>Manufacturer:</b>	Binks, Ringwood Road, Bournemouth, BH11 9LH. UK

**EU Declaration of Conformity**



**We: Binks declare that the above product conforms with the Provisions of:**

Machinery Directive 2006/42/EC

ATEX Directive 94/9/EC

Pressure Equipment Regulations 1999 (SI 1999/2001)

**by complying with the following statutory documents and harmonized standards:**

EN ISO 12100: Safety of Machinery - General Principles for Design

EN ISO 4413: Hydraulic Fluid Power - General Rules and safety requirements

EN ISO 4414: Pneumatic Fluid Power - General Rules and safety requirements

EN 12621: Machinery for the supply and circulation of coating materials under pressure - Safety requirements

EN1127-1: Explosive atmospheres - Explosion prevention - Basic concepts

EN 13463-1: Non electrical equipment for use in potentially explosive atmospheres - Basic methods and requirements

EN 13463-5: Non electrical equipment for use in potentially explosive atmospheres - Protection by constructional safety

Providing all conditions of safe use stated within the product manuals have been complied with and that the final equipment into which this product is installed has been re-assessed as required, in accordance with essential health and safety requirements of the above standards, directives and statutory instruments and also installed in accordance with any applicable local codes of practice.

D Smith (General Manager)  
1/11/12

## Index

### Section

- 1.1 General Description
- 1.2 Operating Principle
- 1.3 Specification
- 1.4 Fitting Selection
  
- 2.1 Installation – General
- 2.2 Installation – Mounting
- 2.3 Installation – Setting to work
  
- 3.1 Assembly Procedure
- 3.2 Assembly Drawing
- 3.3 Parts Lists
  
- 4.1 Important Information
- 4.2 Maintenance
- 4.3 Fault Finding
- 4.4 Spare Parts Lists
  
- 5.1 Accessories

## ***General Description – Section 1.1***

### **Introduction**

A complete range of Binks surge elimination chambers is available to suit both technical and commercial requirements.

The surge elimination chamber is designed to counteract fluctuations in fluid pressure normally seen during a reciprocating pump stroke change over. The fluid chamber is suitable for use with waterborne and conventional paint types.

Both conventional and 'Active' units are available with flow through flushable or single port connections.

Surge elimination chambers should be located on the fluid outlet of the circulating pump for optimum operational performance.

Models are available with a range of standard or customer specified connections, see selection chart (section 1.4) for variants. The required connections are factory fitted and not intended for removal in the field.

### **Active Surge Eliminators**

#### **Features**

- Self compensating design eliminating manual charging with compressed air
- Active control reacts to changes in fluid system pressure
- Flushable fluid chamber
- Fluid connection options available
- Direct mounting to the paint pump
- Increased air volume for improved fluid damping (+ / - 1%)

## ***Operating Principle – Section 1.2***

### **Active Surge Eliminators**

The surge eliminators consist of a lower fluid and upper air chamber separated by a flexible diaphragm. The air chamber is continually supplied with compressed air at a pressure in excess of the maximum desired fluid pressure. Compressed air is used for initial charging and as required to compensate for a change to a higher paint pressure dynamically set on the Paint Pump.

Any air leaks, whilst not desirable are also compensated for.

Fluid is pumped into and around the circulation system filling the lower chamber of the surge eliminator.

At the point of pump stroke change over, the fluid pressure drops causing the diaphragm to deflect and apply pressure to the fluid in the lower chamber, compensating for the momentary reduction in fluid pressure and flow.

The larger air volume available with active surge eliminators greatly improves the performance as fluid surge at pump stroke change over is virtually eliminated. The use of the additional air reservoir capacity is only made possible by the automatic compensation feature to the compressed air pressure.

The follower shaft is permanently connected with the diaphragm and operates a spool controlling the charging and exhausting of compressed air in the upper chamber.

When the diaphragm lifts due to an increase in fluid pressure the spool allows compressed air into the upper chamber until the higher fluid pressure is balanced with air pressure. (See diagram 1)

When the diaphragm falls due to a decrease in fluid pressure the spool allows compressed air to exhaust from the upper chamber to maintain a balance with the new fluid pressure. (See diagram 2)

In normal operation the diaphragm is maintained in its optimum working position within a 'dead band' stroke of 15 mm (See diagram 3) This maintains the maximum effectiveness of the diaphragm to automatically compensate for the changes in fluid pressure at pump stroke change over.

**Operating Principle – Section 1.2**

**Diagram 1**

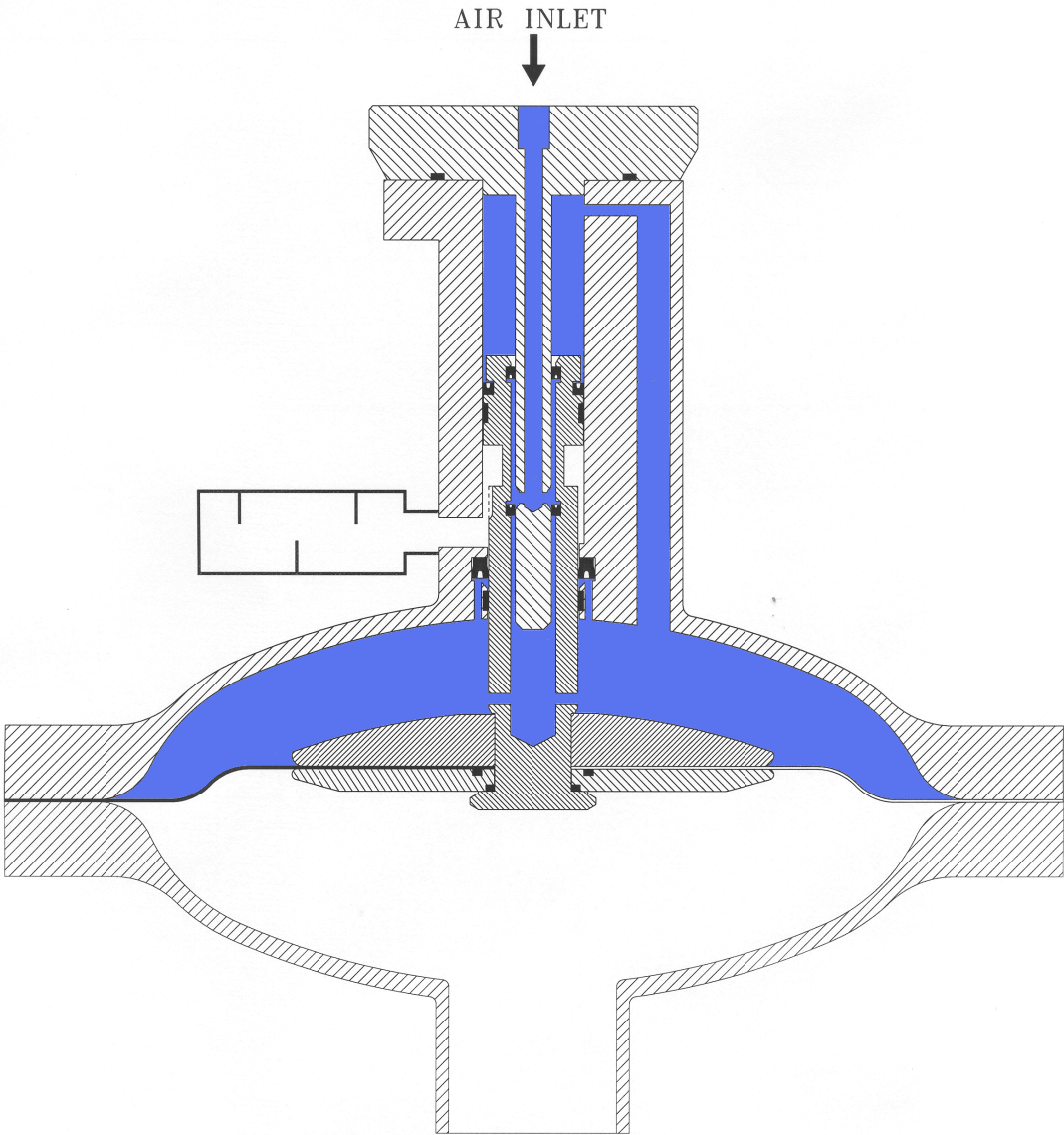

AIR-FILL  
(COMPENSATION FOR ANY AIR LEAKS  
OR RISE IN MATERIAL PRESSURE)

**Operating Principle – Section 1.2**

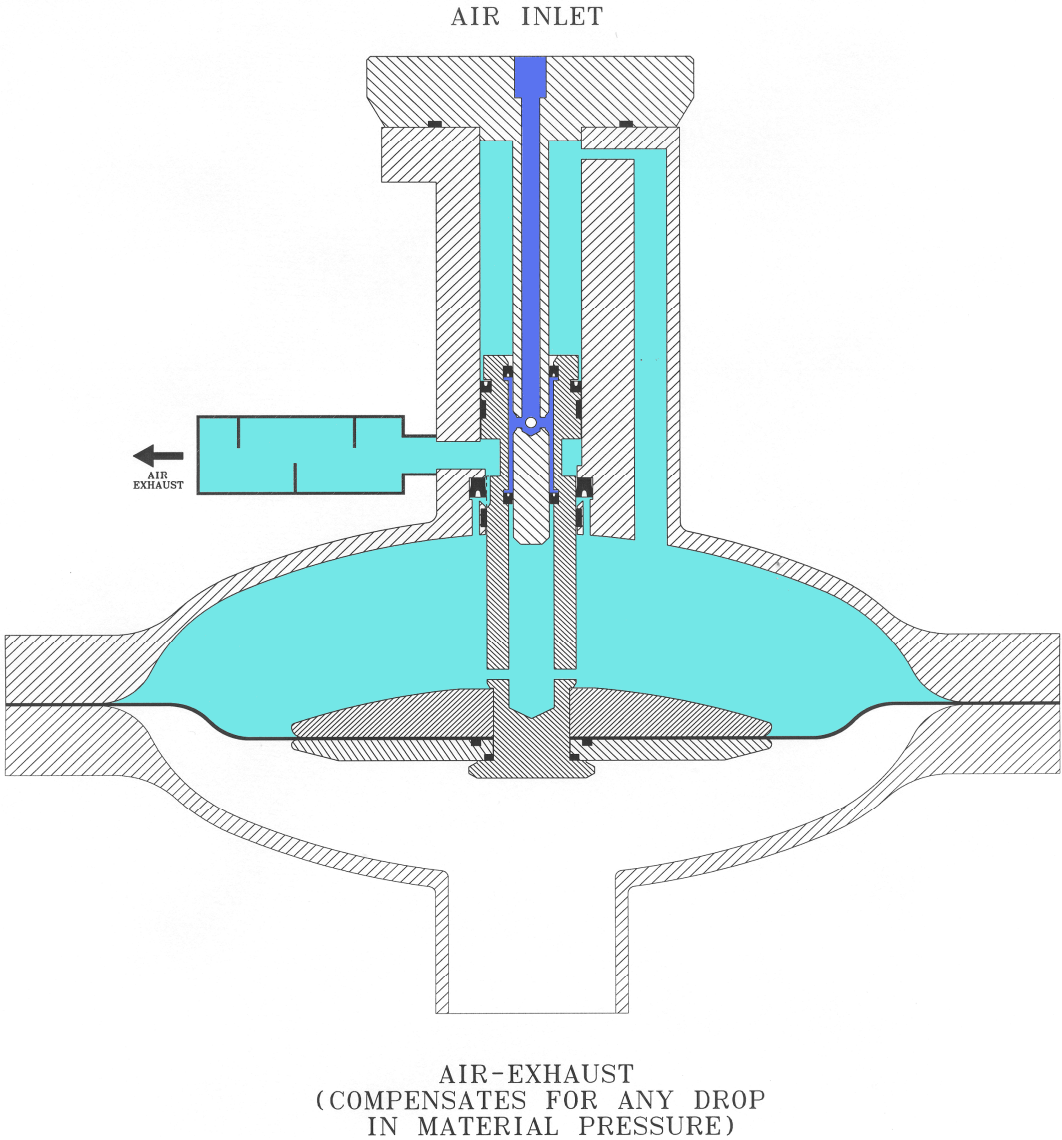

**Operating Principle – Section 1.2**

**Diagram 3**

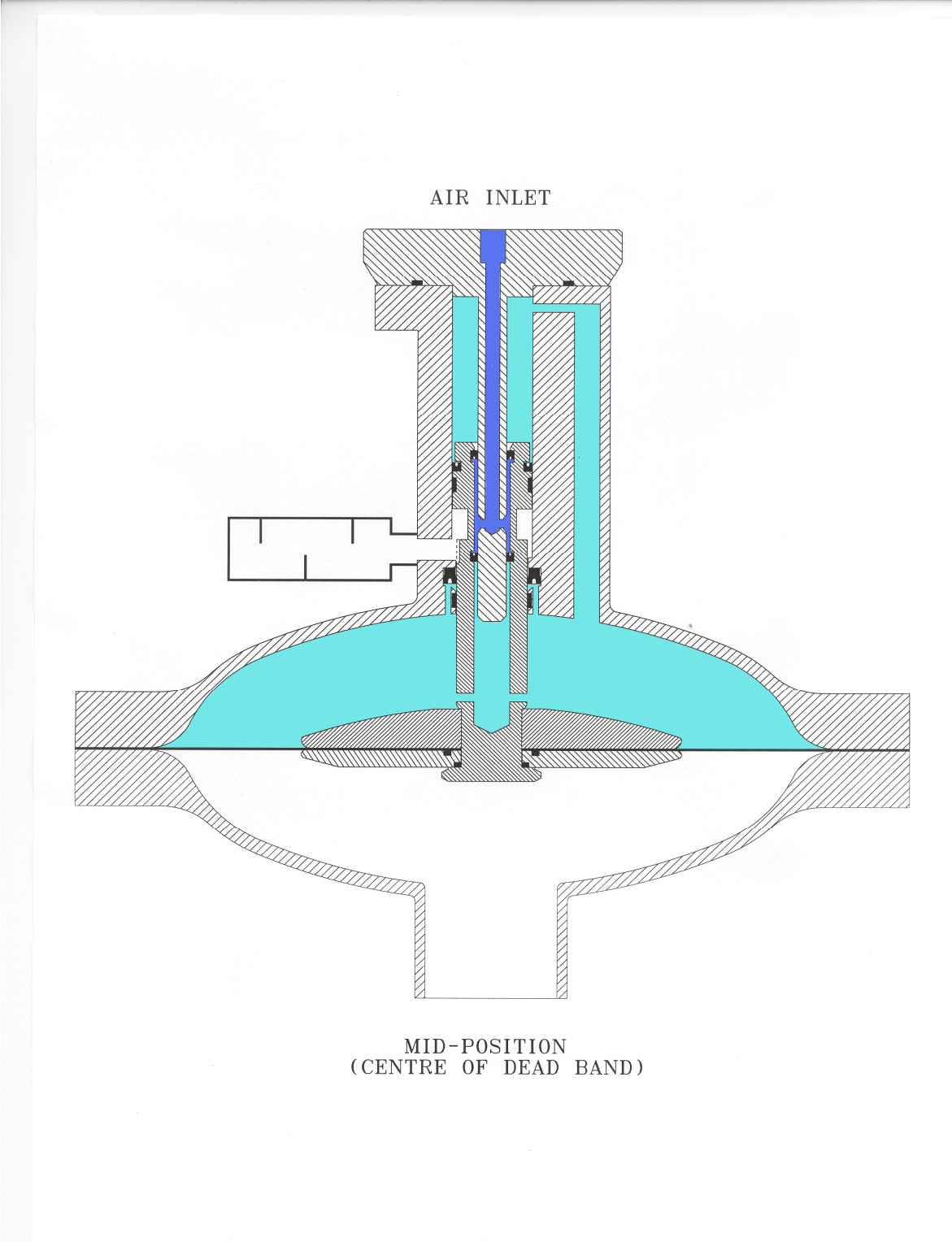



**Specification – Section 1.3**

**Air Connections**

Air Quality required	ISO 8573.1. to 1.5.2	Dirt 0.3 Microns Water +7°C at 7bar Oil 0.1 mg/m <sup>3</sup>
<b>Air Intensifier - 108121</b>		
Input pressure	5 Bar Maximum	¼ BSP
Output pressure	4 x Input pressure	Direct Mounting (or ¼BSP)
Output volume	60 Litres/Min	
<b>Air Reservoir - 108120</b>		
Rated pressure	16 Bar Maximum	
Inlet connection		½ BSP
Pressure relief / exhaust valve	16 Bar set pressure	
<b>Active Chamber</b>		
Input pressure	16 Bar Maximum	1/8 BSP
Exhaust connection		1/4 BSP
Reservoir connection		½ BSP

**Fluid Connections - Examples**

<b>Fluid Chamber</b>		300 Series Stainless Steel
Input pressure	16 Bar Maximum *	
Model 104050 - B - B (was 106934)	Inlet – 2” Sanitary	Outlet – 2” Sanitary
Model 104050 - A - A (was 106943)	Inlet – 2” NB Flange	Outlet – 2” NB Flange
Model 104050 - L - L (was 107017)	Inlet – 1” Sanitary	Outlet – 1” Sanitary
Model 104050 - C - C (was 107046)	Inlet – 1 1/2” Sanitary	Outlet – 1 1/2” Sanitary

\* Higher Working pressures up to 25 Bar are possible if required when combined with an air reservoir which is rated at this pressure.

**Model Selection – Section 1.4**

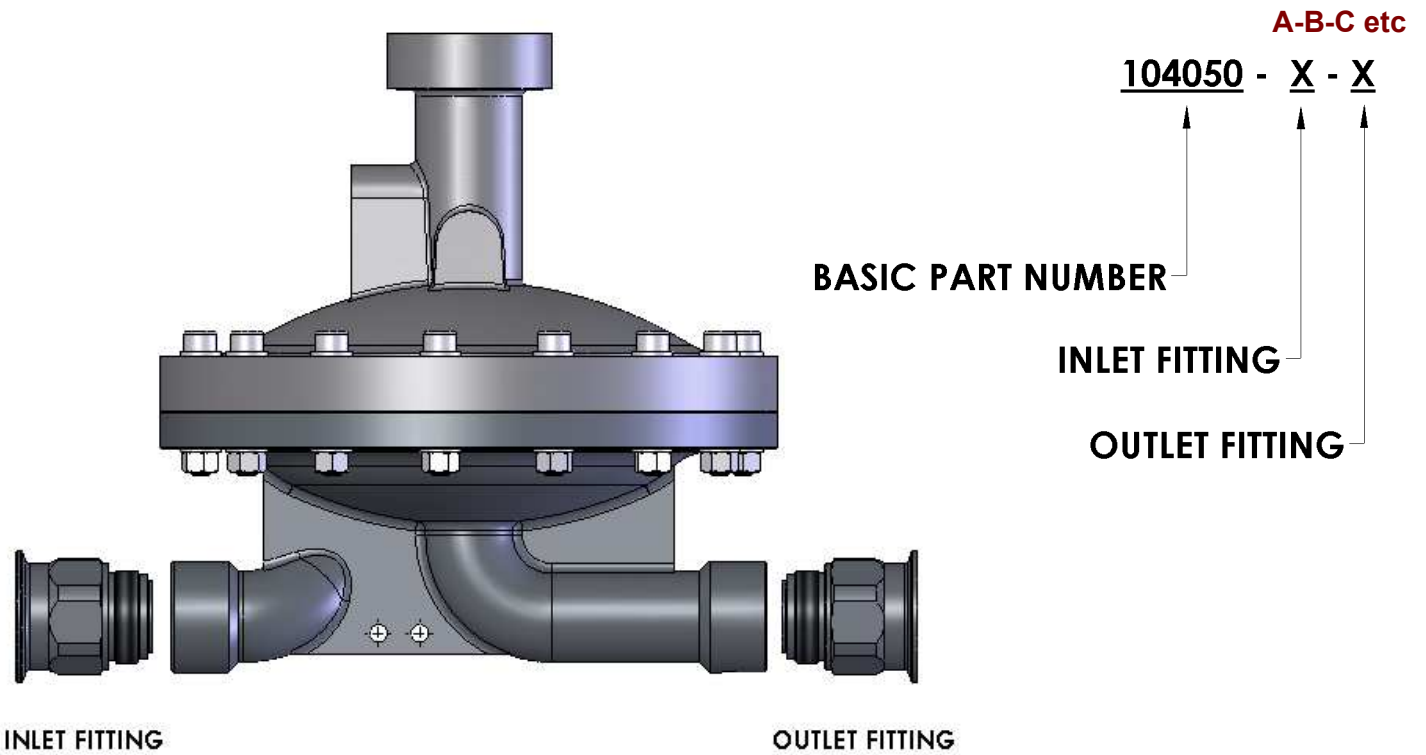

INLET / OUTLET FITTING SELECTION TABLE			
SUFFIX	PART No	DESCRIPTION	REMARKS
A	192553	FITTING - M45 x SLIP FLANGE ASSEMBLY	DN 50 BS4504 PN16
B	<b>192554</b>	<b>FITTING - M45 x 2" SANITARY</b>	<b>STANDARD</b>
C	<b>192555</b>	<b>FITTING - M45 x 1 1/2" SANITARY</b>	<b>STANDARD</b>
D	192556	FITTING - M45 x 1 1/2" NPT (FEMALE)	
E	192557	FITTING - M45 x 1 1/2" BSPT (FEMALE)	
F	192558	FITTING - M45 x 42 MM COMPRESSION COUPLING	DIN 2353
G	192559	FITTING - M45 x 1 1/4" BSP (H)	
H	192560	FITTING - M45 x 1 1/2" BSP (H)	
I	192561	FITTING - M45 x ECOFITTING DN32 (35 O/D)	
J	192562	FITTING - M45 x ECOFITTING DN40 (40 O/D)	
K	192563	FITTING - M45 x ECOFITTING DN50 (50 O/D)	
L	<b>192564</b>	<b>FITTING - M45 x 1" SANITARY</b>	<b>STANDARD</b>
X		NO FITTINGS SUPPLIED	INTERNAL USE

***Installation - General – Section 2.1***

To achieve the best performance from the surge elimination unit the ideal location is direct mounting on the paint pump outlet connection

A suitable bracket should be used to support the surge eliminator in the event that the paint pump or connecting pipework is removed for maintenance operations.

***Installation - Mounting – Section 2.2***

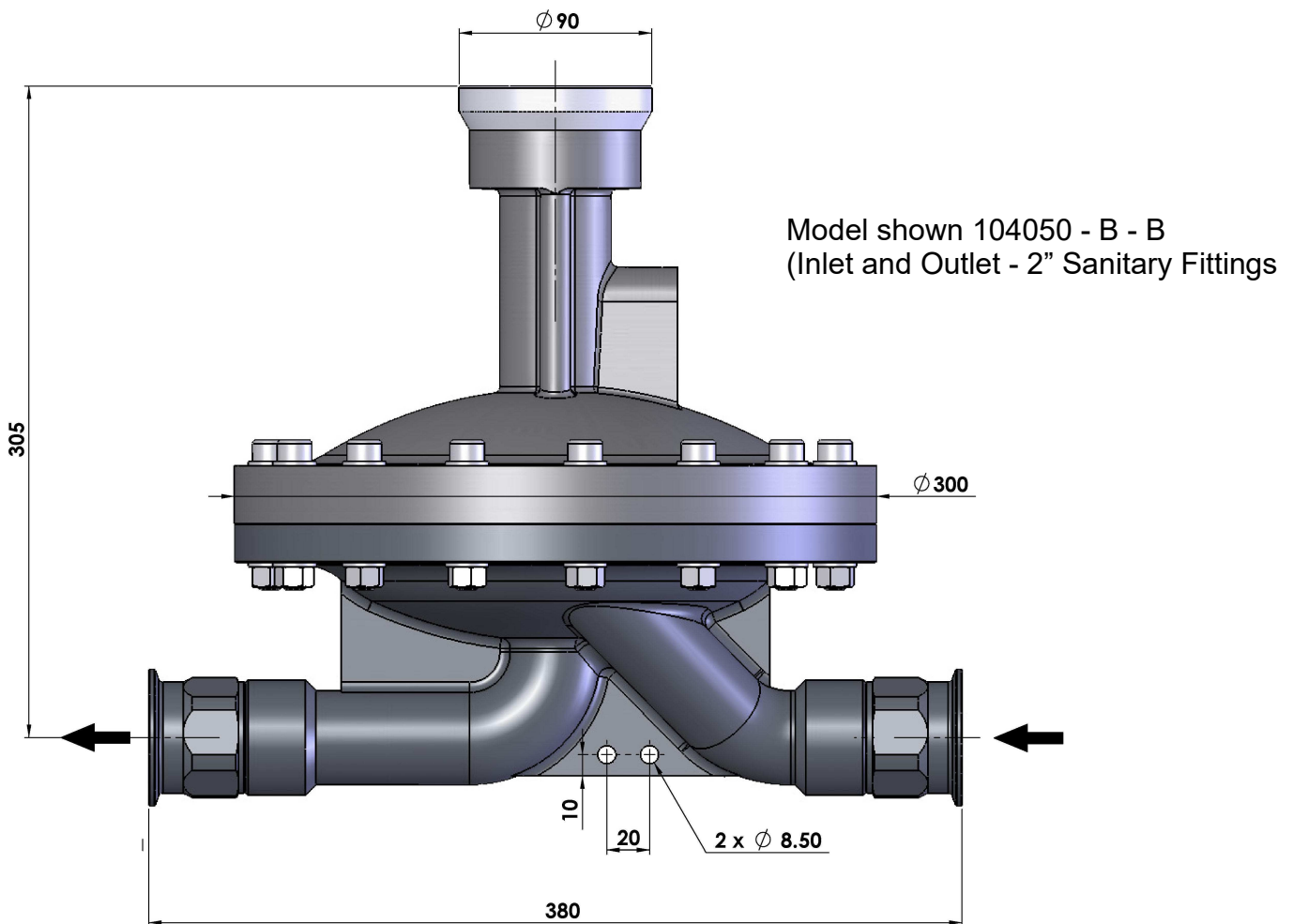

## ***Installation – Setting to Work – Section 2.3***

### **General**

The surge eliminator is pressure tested with demineralised water; the fluid chamber should be flushed with suitable material prior to use.

If any circulating system pressure testing is carried out with the surge eliminator in position then the fluid pressure should not exceed 24 Bar, the air pressure to the upper chamber must be disconnected.

Circulating system flushing can be carried out with the surge eliminator in position; however, the air pressure to the upper chamber should be disconnected, as normal practice is to flush the pipework with a low system back pressure.

Following pressure testing and flushing procedures, the fluid diaphragm may need replacing prior to use in production if the flushed system held contaminants that could impregnate and damage the diaphragm.  
Ensure that the unit is correctly grounded to earth to prevent any 'static' build up.

### **Air Connections**

Connect the air reservoir hose supplied with the Air Reservoir Kit (108120) to the top dish ½ BSP port. The air reservoir should be mounted on a suitable bracket in close proximity to the surge eliminator so that the connecting hose is not stressed. (Minimum hose bore ½ Dia - Maximum length of hose 1 metre)  
A suitable bracket (207968) is available to mount the reservoir to the pump.

Connect a suitable compressed air supply to the 1/8 BSP port on the top dish. The air supply pressure should be set at 1Bar greater than the maximum desired fluid pressure from the paint pump.

When the optional air intensifier kit (108121) is mounted on the top dish, connect a suitable compressed air supply to the 1/4 BSP port on the intensifier. The incoming air supply should be set at 4.5 Bar. The particulate contaminate in the compressed air should be less than 0.3 microns to ensure reliability of the intensifier.

### **Operation**

After checking that all connections are made correctly:

- Start the paint pump
- Turn on the air supply to the intensifier / top dish.

The intensifier will operate rapidly until the top dish and reservoir is charged to equal the paint pumping pressure.

**Installation – Setting to Work – Section 2.3**

ACTIVE SURGE ELIMINATOR CONNECTIONS

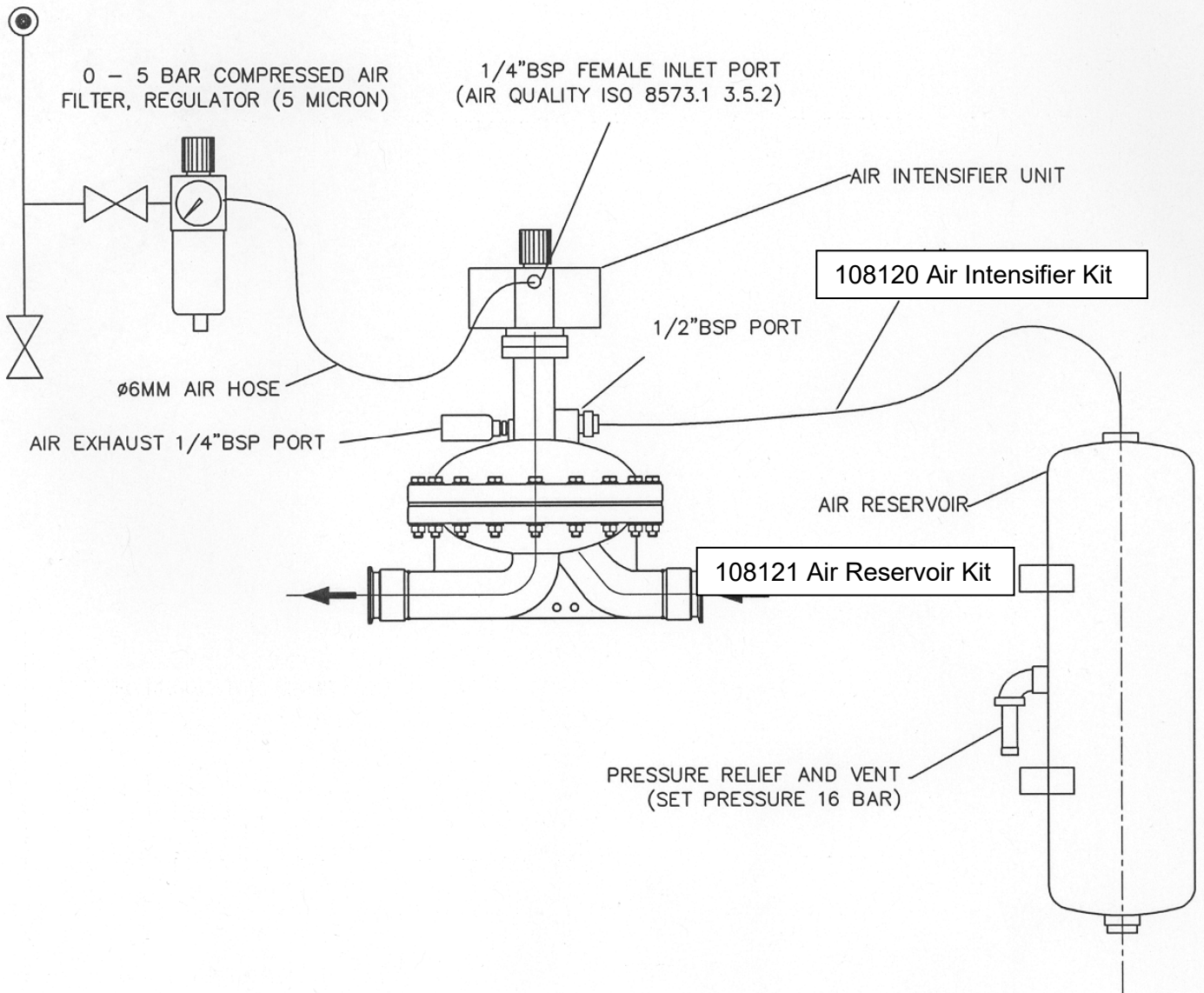

## **Assembly Procedure – Section 3.1**

### **192012 (11) Cap and Centre Shaft Sub-assembly**

**(For reference only, this part is supplied as an assembly)**

1. *Fit O Ring (161975) into centre shaft retainer (192033) groove*
2. *Place centre shaft (192034) into position on retainer and fasten with 3 off M3 Cap Screws (163937) ensure shaft is square and concentric to assembly face*

### **1. Outer Sleeve Sub-assembly**

1. Fit 2 off O Rings (25)161973 to the outside diameter of the sleeve(10)192013
2. Fit bearing strip (3)192018 to internal outer groove. Ensure the bearing strip is seated correctly by temporarily inserting the follower shaft (6)192015 applying pressure to the bearing strip.
3. Fit U seal (23)162689 to internal inner groove, 'U' facing outwards
4. Apply grease (Kluber ISO Flex Topas NB52) to the bearing strip, U seal and internal bore.

### **2. Follower Shaft Sub-assembly**

1. Insert seal (22)192690 into inner top groove of follower shaft (6)192015. Note U section to face into bore as shown on drawing.
2. Using *assembly tool 192042* insert seal (22)192690 into follower shaft bore. Note U section to face into bore as drawing
3. Fit U seal (24)162688 into outer top groove of follower shaft. U seal facing screwdriver slot
4. Fit bearing strip (3)192018 into groove. Ensure bearing strip is seated correctly by temporarily inserting the follower shaft (bearing end first) into the outer sleeve and apply pressure all round the bearing strip. Apply grease (Kluber ISO Flex Topas NB52) to the bearing strip and U seal. Also apply a light coating of grease onto the outside diameter of the shaft.

### **3. Sub-assembly**

Insert follower shaft sub-assembly into outer sleeve sub-assembly. Take care that the bearing strip is located correctly on insertion.

## ***Assembly Procedure – Section 3.2***

### **4. Sub-assembly**

Apply a light coating of grease to the O rings and mating bore of the top dish  
(3) 204248 Insert the outer sleeve/follower shaft assembly into the top dish.

### **5. Main Assembly**

1. Hold *assembly tool 192043* in a vice (with the screwdriver facing upwards).
2. Position top dish upside down over the assembly tool. Locate follower shaft slot firmly onto the assembly tool screwdriver blade.
3. Hold the diaphragm (5)192474 and apply a small amount of grease onto the diaphragm connecting thread, assemble into the follower shaft thread. (Take care not to cross the thread) Secure by gripping the outside edge of the diaphragm to apply sufficient force to lock the thread in position.

Place top dish into workbench. Apply grease to O ring (26)161972 and fit into groove of cap and centre shaft assembly (11)192012. Coat shaft with grease (Kluber ISO Flex Topas NB52) and insert into top of follower shaft. Secure with 4 off M6 Cap Screw (12)164706 and spring washers (19)165087

### **7 Main Dish Assembly**

Place O-ring (30)192232 into groove in bottom dish and mount the top dish assembly. (Take care not to disturb the o-ring)

Secure the top and bottom dishes together with the 15 off M10 x 60 lg Caphead Screws (16)(165569) 30 off washers (17)165135 and 15 off Hexagon nuts (18)163127.

Tighten opposed bolts to 33 N-M (25 foot-pounds) in stages to maintain an even clamping force

**VIEW SHOWING ORIENTATION OF SEALS**

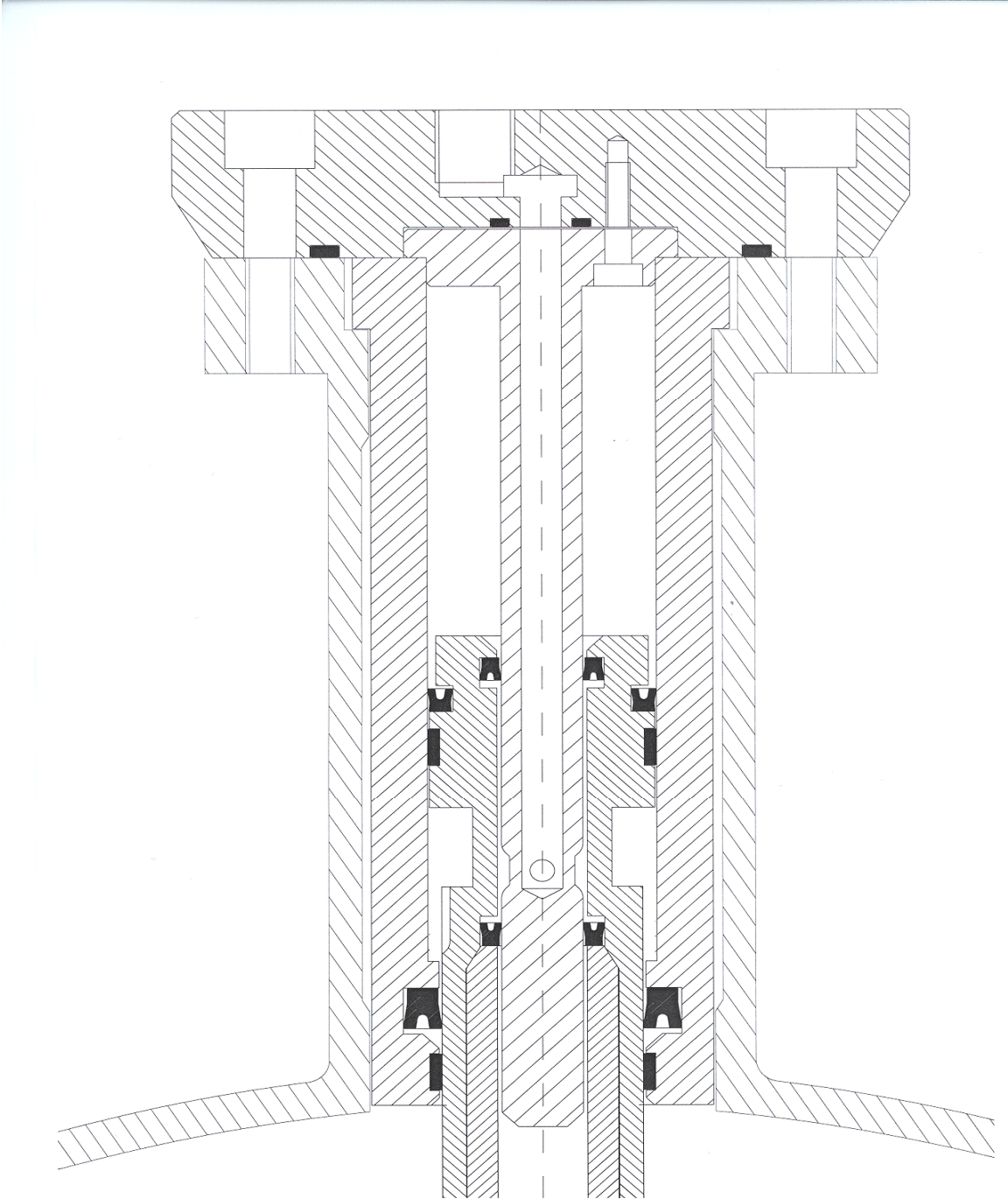



**Assembly Drawing – Section 3.2**

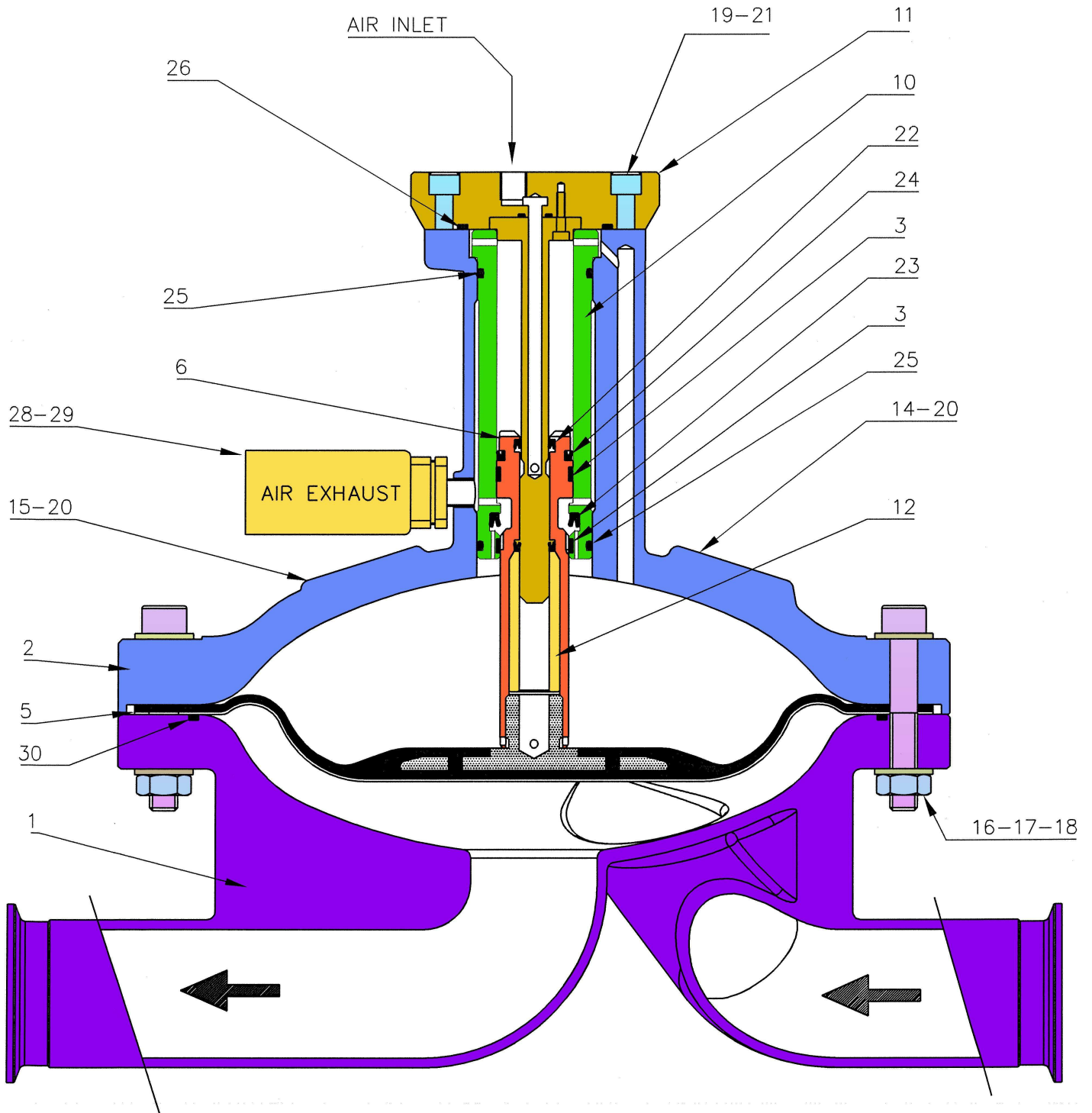

**Parts Lists – Section 3.3**

<b>Parts List - 104050 - X - X (Basic Unit)</b>				
<b>Item</b>	<b>Part No.</b>	<b>Description</b>	<b>Qty</b>	<b>Remarks</b>
1	204255	Bottom Dish - Flushable [Select Required Inlet / Outlet Fittings]	1	Assembly Ref. 104050 -X-X
2	204248	Top Dish	1	
3	192018	Bearing Strip	2	
4	See Table	Inlet Connection	1	
		Outlet Connection	1	
5	192474	Moulded Composite Diaphragm	1	
6	192015	Follower Shaft	1	
7				
8	161981	O-Ring	2	Connection Seal
9				
10	192013	Outer Sleeve	1	
11	192012	Centre Shaft Assembly	1	
12	192011	Centre Seal Retainer	1	
13				
14	191365	Nameplate	1	
15	220317	Pressure Warning Label	1	
16	165569	M10 x 60 Cap Head Screw	15	
17	165135	Ø10 Plain Washer	30	
18	163127	M10 Hex Nut	15	
19	165087	Ø6 Spring Washer	4	
20	164838	No. 2 Drive Screw	4	
21	164706	M6 x 25 Cap Head Screw	4	
22	162690	Ø10 x 15 U Seal	2	
23	162689	Ø33 x 25 U Seal	1	
24	162688	Ø28 x 22 U Seal	1	
25	161973	37.6 I/D x 2.4 Section O Ring	2	
26	161972	51.6 I/D x 2.4 Section O Ring	1	
27	192030	½" BSP (T-H) Nipple (for reservoir)	1	Not Shown
28	192032	3/8" – ¼" BSP Taper Nipple	1	
29	173231	Air Silencer – 3/8" BSP (F)	1	
30	192232	Ø 247 O-Ring	1	

***Important Information - Section 4.1*****Directions for Working Safety**

This Product has been constructed according to advanced technological standards and is operationally reliable. Damage may, however, result if it is used incorrectly by untrained persons or used for purposes other than those for which it was constructed.

The locally current regulations for safety and prevention of accidents are valid for the operation of this product under all circumstances.

International, national and company safety regulations are to be observed for the installation and operation of this product, as well as the procedures involved in maintenance, repairs and cleaning.

These instructions are intended to be read, understood and observed in all points by those responsible for this product. These operating and maintenance instructions are intended to ensure trouble free operation. Therefore, it is recommended to read these instructions carefully before start-up. Binks cannot be held responsible for damage or malfunctions resulting from the non-observance of the operating instructions. These instructions including regulations and technical drawings may not be copied, distributed, used for commercial purposes or given to others either in full or in part without the consent of Binks.

We reserve the right to alter drawings and specifications necessary for the technical improvement of this product without notice.

**High Pressure/Electrostatic Warning**

High pressure equipment can be dangerous if used incorrectly, serious bodily injury may occur if the following instructions are ignored. Installation and maintenance should only be carried out by suitably qualified personnel.

1. Before attempting any work on a high-pressure system ensure material pump, hydraulics, compressed air motor are isolated where relevant.
2. Relieve all pressure from the system. Note: It is possible for pressure to get locked into a system, therefore ensure all sections of the system are checked thoroughly for remaining pressure.
3. Take care when releasing fittings
4. Always replace worn hoses immediately
5. Never plug a leak with your finger, adhesive tape or other stop gap devices
6. Always ensure equipment is suitably earthed before running, to avoid any chance of electrostatic build up.

## ***Maintenance – Section 4.2***

### **Operational maintenance**

A feature of the active surge eliminator is that regular upper chamber charging is not required as the integral air valve operation ensures that the upper chamber air pressure always matches the lower chamber material pressure.

A regular check to ensure that the unit is operating correctly can be made by observing the paint system pressure gauge for fluctuations in pressure and noting whether the unit is continuously filling or exhausting air.

### **Preventative Maintenance**

As the unit usually operates continually for 24 hours per day with the paint pump, it is recommended to inspect the diaphragm by removing the top dish to check for any creases, stressing or damage on the PTFE side of diaphragm every 6 months, replace if damaged. (This is particularly important when used with solvent based materials) The diaphragm should be replaced on an annual basis.

It is recommended that the unit is overhauled and all seals, o-rings and bearing strips are replaced on an annual basis.

Note: Before attempting any maintenance ensure that all relevant directions for working safety are followed.

***Fault Finding – Section 4.3***

<b>Problem</b>	<b>Cause</b>	<b>Action</b>
Paint pressure pulsating	Insufficient or lack of air pressure in upper chamber	Check air supply pressure is on and higher than paint pressure
Paint leaking from air exhaust	Diaphragm ruptured	Replace diaphragm
Paint / Air leaking from diaphragm spacer connector	Diaphragm ruptured	Replace diaphragm
Air permanently leaking form air exhaust	Damaged seal	Replace lip seal (162689)
Air intensifier continues to run following charging to correct air pressure	Air intensifier faulty	Replace
Air intensifier continues to run following charging to correct air pressure	Shaft seals leaking	Replace seals and overhaul unit
Air intensifier continues to run following charging to correct air pressure	Air leaking from reservoir kit, hose or pressure relief valve (173712)	Soap and bubble test all joints, plugs and valves. Tighten or remove and reseal if required. Renew relief valve if leaking. (knurled top should be free to move and not acting on the spring)

**Spare Parts List – Section 4.4**

<b>250526 Overhaul Kit for 104050</b>				
<b>Item</b>	<b>Part No.</b>	<b>Description</b>	<b>Qty</b>	<b>Remarks</b>
3	192018	Bearing Strip	2	
5	192474	Moulded Composite Diaphragm	1	
22	162690	Ø10 x 15 U Seal	2	
23	162689	Ø33 x 25 U Seal	1	
24	162688	Ø28 x 22 U Seal	1	
25	161973	37.6 I/D x 2.4 Section O Ring	2	
26	161972	51.6 I/D x 2.4 Section O Ring	1	
30	192232	Ø247 O-Ring	1	

<b>250087 Diaphragm Replacement Kit for 104050</b>				
<b>Item</b>	<b>Part No.</b>	<b>Description</b>	<b>Qty</b>	<b>Remarks</b>
5	192474	Moulded Composite Diaphragm	1	
30	192232	Ø247 O-Ring	1	

<b>Assembly Tools</b>			
<b>Part No.</b>	<b>Description of Use</b>	<b>Qty</b>	<b>Remarks</b>
192042	To insert 162690 'U' seal (Ø10 x 15) into bottom of 192015 Follower shaft	1	Nylon
192043	To tighten 192017 Retaining pin to clamp Diaphragms	1	Steel
192194	To allow 162689 'U' seal (Ø 33 x 25) to be inserted into 192013 Outer sleeve	1	Nylon
192195	To allow 162690 'U' seal (Ø10 x 15) to be inserted into top inside groove of 192015 Follower shaft	1	Nylon
192109	<i>Set of all above tools</i>	<i>1 Set</i>	

**Accessories – Section 5.1**

Accessories		
Part No.	Description	Remarks
108120	Air Reservoir Kit	See Below
108121	Air Intensifier Kit	See Below
207967	Reservoir pump mounting bracket	For 60 GPM / 45 GPM Pump
207969	Surge Eliminator Support Stand	For 104050
192009	1½" Sanitary Clamp	
192544	2" Sanitary Clamp	
192029	2" Sanitary Gasket	
192008	1½" Sanitary Gasket	
173712	16 Bar Pressure Relief Valve	Spare valve for 108120 reservoir kit

**104050P-X-X Denotes Package of below Items**

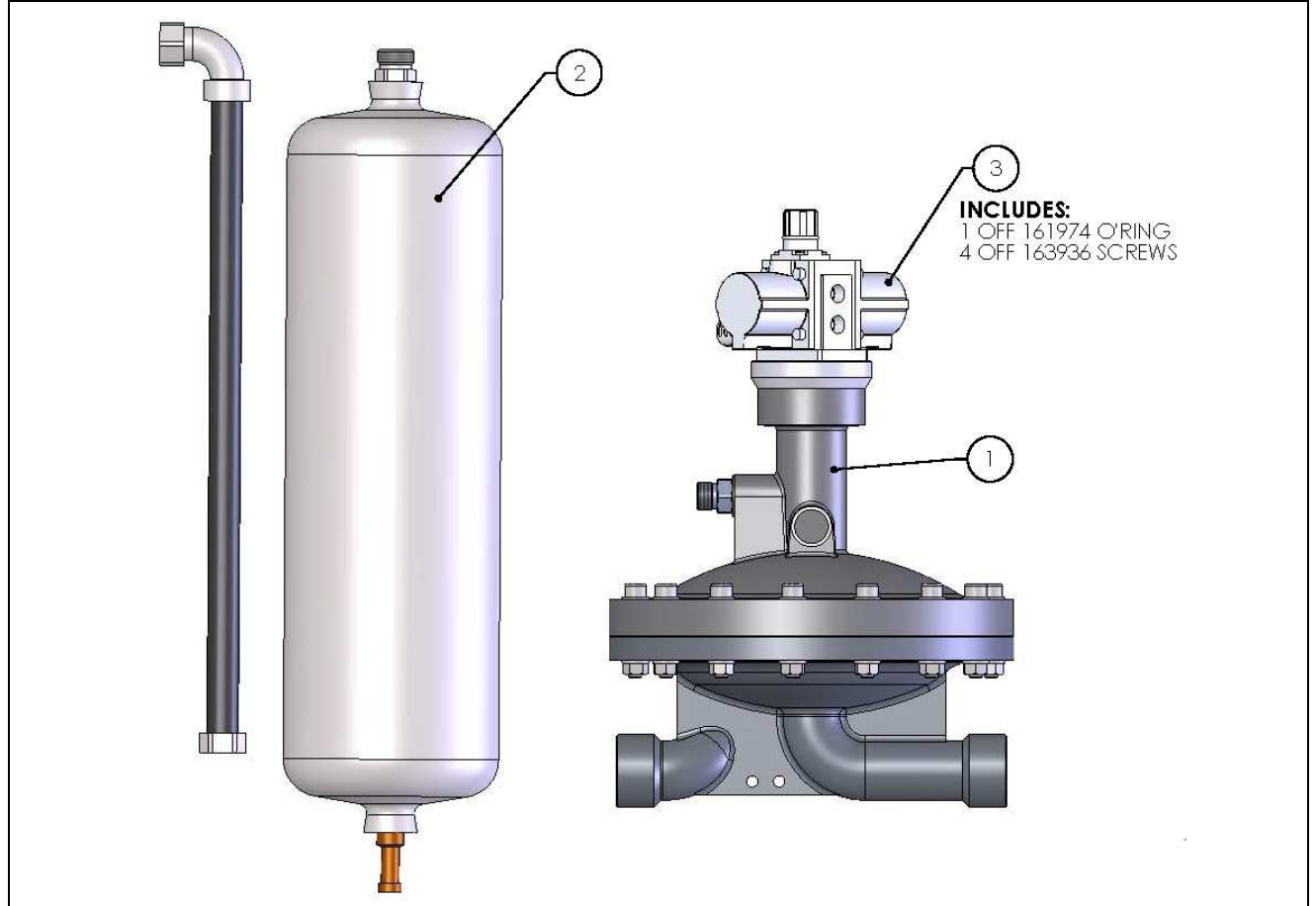

Item	Part No.	Description	Remarks
1	104050-X-X	Active Surge Eliminator	
2	108120	Air Reservoir Kit	
3	108121	Air Intensifier Kit	

## WARRANTY POLICY

This product is covered by Carlisle Fluid Technologies' materials and workmanship limited warranty. The use of any parts or accessories, from a source other than Carlisle Fluid Technologies, will void all warranties. Failure to reasonably follow any maintenance guidance provided, may invalidate any warranty.

For specific warranty information please contact Carlisle Fluid Technologies.

Carlisle Fluid Technologies is a global leader in innovative finishing technologies. Carlisle Fluid Technologies reserves the right to modify equipment specifications without prior notice.

DeVilbiss®, Ransburg®, MS®, BGK®, and Binks® are registered trademarks of Carlisle Fluid Technologies, Inc.

© 2020 Carlisle Fluid Technologies, Inc.

All rights reserved.

For technical assistance or to locate an authorised distributor, contact one of our international sales and customer support locations below.

<b>Region</b>	<b>Industrial / Automotive</b>	<b>Automotive Refinishing</b>
<b>Americas</b>	Tel: 1-888-992-4657 Fax: 1-888-246-5732	Tel: 1-800-445-3988 Fax: 1-800-445-6643
<b>Europe, Africa, Middle East, India</b>	Tel: +44 (0)1202 571 111 Fax: +44 (0)1202 573 488	
<b>China</b>	Tel: +8621-3373 0108 Fax: +8621-3373 0308	
<b>Japan</b>	Tel: +81 45 785 6421 Fax: +81 45 785 6517	
<b>Australia</b>	Tel: +61 (0) 2 8525 7555 Fax: +61 (0) 2 8525 7575	

For the latest information about our products, visit [www.carlisleft.com](http://www.carlisleft.com)