

# Ransburg Aerbell 33™ Rotary Atomizer

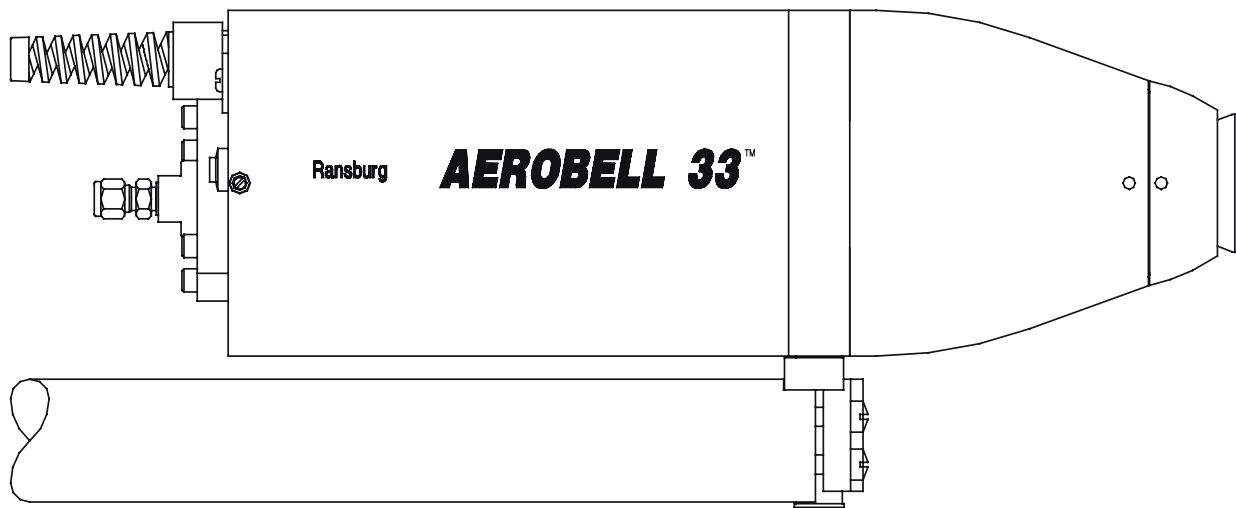

Model: AER5000/AER5001

**IMPORTANT:** Before using this equipment, carefully read SAFETY PRECAUTIONS and all instructions in this manual. Keep this Service Manual for future reference.

**NOTE:** This manual has been changed from revision **LN-9521-00.4** to revision **LN-9521-00-R5**. Reasons for this change are noted under “Manual Change Summary” inside the back cover of this manual.

# CONTENTS

<b>SAFETY:</b>	<b>5-9</b>
<a href="#">Safety Precautions</a> .....	5
<a href="#">Hazards / Safeguards</a> .....	6
<b>INTRODUCTION:</b>	<b>10-15</b>
<a href="#">Features</a> .....	10
<a href="#">General Description</a> .....	10
<a href="#">Specification</a> .....	12
<a href="#">Graphs</a> .....	13
<b>INSTALLATION:</b>	<b>16-18</b>
<a href="#">Air Filter Installation</a> .....	16
<a href="#">Air Pressure Requirements</a> .....	16
<a href="#">Air Filtration Requirements</a> .....	16
<a href="#">Mounting</a> .....	17
<a href="#">Fluid Connections</a> .....	17
<a href="#">Electrical Connections</a> .....	17
<a href="#">Speed Monitor Connections</a> .....	17
<a href="#">Interlocks</a> .....	18
<b>OPERATION:</b>	<b>19-23</b>
<a href="#">Coating Materials</a> .....	19
<a href="#">Fluid Flow Rate Control</a> .....	19
<a href="#">Fluid Valve Control</a> .....	22
<a href="#">Turbine Speed</a> .....	22
<a href="#">Bearing Air Adjustment</a> .....	22
<a href="#">Shaping Air</a> .....	23
<a href="#">Brake Air</a> .....	23
<a href="#">Electrostatic Voltage</a> .....	23
<a href="#">Target Distance</a> .....	23
<b>MAINTENANCE:</b>	<b>24-36</b>
<a href="#">Cleaning Procedures</a> .....	24
<a href="#">Vibration Noise</a> .....	26
<a href="#">Turbine Repair &amp; Rebuild</a> .....	26
<a href="#">High Voltage Connections</a> .....	26
<a href="#">Air Filters/Element Replacement</a> .....	26
<a href="#">Valves</a> .....	26
<a href="#">General</a> .....	26
<a href="#">Preventive Maintenance</a> .....	26
<a href="#">High Performance Thermoplastic Bell Cup Preventive Maintenance</a> .....	28
<a href="#">Bell Cup Cleaning</a> .....	28
<a href="#">Bell Cup Testing (Non-Rotating)</a> .....	29
<a href="#">Operator / Maintenance Warnings</a> .....	30
<a href="#">Low Voltage Test</a> .....	31
<a href="#">Disassembly Procedures</a> .....	31
<a href="#">Troubleshooting Guide</a> .....	34

*(Continued On Next Page)*

# CONTENTS (Cont.)

<b>PARTS IDENTIFICATION:</b>	<b>37-48</b>
<a href="#">Aerobell 33 Cross Section</a> .....	37
<a href="#">Aerobell 33 Model Identification</a> .....	39
<a href="#">Aerobell 33 Parts List</a> .....	41
<a href="#">AER4004-01 Manifold Assembly - Parts List</a> .....	43
<a href="#">Fluid Manifold Assembly - Parts List</a> .....	44
<a href="#">Waterborne Fluid Manifold Assembly - Parts List</a> .....	46
<a href="#">Recommended Spare Parts</a> .....	48
<a href="#">Service Kits</a> .....	48
<a href="#">Available Tools</a> .....	48
<b>APPENDIX:</b>	<b>49-52</b>
<a href="#">Paint and Solvent Specifications</a> .....	49
<a href="#">Guide To Usable Solvent Selection</a> .....	49
<a href="#">Viscosity Conversion Chart</a> .....	50
<a href="#">Volumetric Content of Hose or Tube (English Units)</a> .....	52
<a href="#">Volumetric Content of Hose or Tube (Metric Units)</a> .....	52
<b>MANUAL CHANGE SUMMARY:</b>	<b>53</b>
<a href="#">Manual Changes</a> .....	53

# SAFETY

## SAFETY PRECAUTIONS

Before operating, maintaining or servicing any electrostatic coating system, read and understand all of the technical and safety literature for your products. This manual contains information that is important for you to know and understand. This information relates to **USER SAFETY** and **PREVENTING EQUIPMENT PROBLEMS**. To help you recognize this information, we use the following symbols. Please pay particular attention to these sections.

### WARNING

A **WARNING!** states information to alert you to a situation that might cause serious injury if instructions are not followed.

### CAUTION

A **CAUTION!** states information that tells how to prevent damage to equipment or how to avoid a situation that might cause minor injury.

### NOTE

A **NOTE** is information relevant to the procedure in progress.

While this manual lists standard specifications and service procedures, some minor deviations may be found between this literature and your equipment. Differences in local codes and plant requirements, material delivery requirements, etc., make such variations inevitable. Compare this manual with your system installation drawings and associated equipment manuals to reconcile such differences.

Careful study and continued use of this manual will provide a better understanding of the equipment and process, resulting in more efficient operation, longer trouble-free service and faster, easier troubleshooting. If you do not have the manuals and safety literature for your equipment, contact your local Carlisle Fluid Technologies representative or Carlisle Fluid Technologies technical support.

### WARNING



- The user **MUST** read and be familiar with the Safety Section in this manual and the safety literature therein identified.
- This equipment is intended to be used by trained personnel **ONLY**.
- This manual **MUST** be read and thoroughly understood by **ALL** personnel who operate, clean or maintain this equipment! Special care should be taken to ensure that the **WARNINGS** and safety requirements for operating and servicing the equipment are followed. The user should be aware of and adhere to **ALL** local building and fire codes and ordinances as well as **NFPA-33 AND EN 50177 SAFETY STANDARDS, LATEST EDITION**, or applicable country safety standards, prior to installing, operating, and/or servicing this equipment.

### WARNING

- The hazards shown on the following pages may occur during the normal use of this equipment.



Repairs may only be performed by authorized personnel.

<p><b>AREA</b> Tells where hazards may occur.</p>	<p><b>HAZARD</b> Tells what the hazard is.</p>	<p><b>SAFEGUARDS</b> Tells how to avoid the hazard.</p>
<p><b>Spray Area</b></p> 	<p><b>Fire Hazard</b></p> <p>Improper or inadequate operation and maintenance procedures will cause a fire hazard.</p> <p>Protection against inadvertent arcing that is capable of causing fire or explosion is lost if any safety interlocks are disabled during operation. Frequent Power Supply or Controller shutdown indicates a problem in the system requiring correction.</p>	<p>Fire extinguishing equipment must be present in the spray area and tested periodically.</p> <p>Spray areas must be kept clean to prevent the accumulation of combustible residues.</p> <p>Smoking must never be allowed in the spray area.</p> <p>The high voltage supplied to the atomizer must be turned off prior to cleaning, flushing or maintenance.</p> <p>Spray booth ventilation must be kept at the rates required by NFPA-33, OSHA, country, and local codes. In addition, ventilation must be maintained during cleaning operations using flammable or combustible solvents.</p> <p>Electrostatic arcing must be prevented. Safe sparking distance must be maintained between the parts being coated and the applicator. A distance of 1 inch (25.4mm) for every 10kV of output voltage is required at all times.</p> <p>Test only in areas free of combustible material. Testing may require high voltage to be on, but only as instructed.</p> <p>Non-factory replacement parts or unauthorized equipment modifications may cause fire or injury. If used, the key switch bypass is intended for use only during setup operations. Production should never be done with safety interlocks disabled.</p> <p>The paint process and equipment should be set up and operated in accordance with NFPA-33, NEC, OSHA, local, country, and European Health and Safety Norms.</p>

<p><b>AREA</b> Tells where hazards may occur.</p>	<p><b>HAZARD</b> Tells what the hazard is.</p>	<p><b>SAFEGUARDS</b> Tells how to avoid the hazard.</p>
<p><b>Spray Area</b></p> 	<p><b>Explosion Hazard</b></p> <p>Improper or inadequate operation and maintenance procedures will cause a fire hazard.</p> <p>Protection against inadvertent arcing that is capable of causing fire or explosion is lost if any safety interlocks are disabled during operation.</p> <p>Frequent Power Supply or Controller shutdown indicates a problem in the system requiring correction.</p>	<p>Electrostatic arcing must be prevented. Safe sparking distance must be maintained between the parts being coated and the applicator. A distance of 1 inch (25.4mm) for every 10kV of output voltage is required at all times.</p> <p>Unless specifically approved for use in hazardous locations, all electrical equipment must be located <b>outside</b> Class I or II, Division 1 or 2 hazardous areas, in accordance with NFPA-33.</p> <p>Test only in areas free of flammable or combustible materials.</p> <p>The current overload sensitivity (if equipped) <b>MUST</b> be set as described in the corresponding section of the equipment manual. Protection against inadvertent arcing that is capable of causing fire or explosion is lost if the current overload sensitivity is not properly set. Frequent power supply shutdown indicates a problem in the system which requires correction.</p> <p>Always turn the control panel power off prior to flushing, cleaning, or working on spray system equipment.</p> <p>Before turning high voltage on, make sure no objects are within the safe sparking distance.</p> <p>Ensure that the control panel is interlocked with the ventilation system and conveyor in accordance with NFPA-33, EN 50176.</p> <p>Have fire extinguishing equipment readily available and tested periodically.</p>
<p><b>General Use and Maintenance</b></p> 	<p>Improper operation or maintenance may create a hazard.</p> <p>Personnel must be properly trained in the use of this equipment.</p>	<p>Personnel must be given training in accordance with the requirements of NFPA-33, EN 60079-0.</p> <p>Instructions and safety precautions must be read and understood prior to using this equipment.</p> <p>Comply with appropriate local, state, and national codes governing ventilation, fire protection, operation maintenance, and housekeeping. Reference OSHA, NFPA-33, EN Norms and your insurance company requirements.</p>

<p><b>AREA</b> Tells where hazards may occur.</p>	<p><b>HAZARD</b> Tells what the hazard is.</p>	<p><b>SAFEGUARDS</b> Tells how to avoid the hazard.</p>
<p><b>Spray Area / High Voltage Equipment</b></p> 	<p><b>Electrical Discharge</b></p> <p>There is a high voltage device that can induce an electrical charge on ungrounded objects which is capable of igniting coating materials.</p> <p>Inadequate grounding will cause a spark hazard. A spark can ignite many coating materials and cause a fire or explosion.</p>	<p>Parts being sprayed and operators in the spray area must be properly grounded.</p> <p>Parts being sprayed must be supported on conveyors or hangers that are properly grounded. The resistance between the part and earth ground must not exceed 1 megohm. (Refer to NFPA-33.)</p> <p>Operators must be grounded. Rubber soled insulating shoes should not be worn. Grounding straps on wrists or legs may be used to assure adequate ground contact.</p> <p>Operators must not be wearing or carrying any ungrounded metal objects.</p> <p>When using an electrostatic handgun, operators must assure contact with the handle of the applicator via conductive gloves or gloves with the palm section cut out.</p> <p><b>NOTE: REFER TO NFPA-33 OR SPECIFIC COUNTRY SAFETY CODES REGARDING PROPER OPERATOR GROUNDING.</b></p> <p>All electrically conductive objects in the spray area, with the exception of those objects required by the process to be at high voltage, must be grounded. Grounded conductive flooring must be provided in the spray area.</p> <p>Always turn off the power supply prior to flushing, cleaning, or working on spray system equipment.</p> <p>Unless specifically approved for use in hazardous locations, all electrical equipment must be located <b>outside</b> Class I or II, Division 1 or 2 hazardous areas, in accordance with NFPA-33.</p> <p>Avoid installing an applicator into a fluid system where the solvent supply is ungrounded.</p> <p>Do not touch the applicator electrode while it is energized.</p>



<p><b>AREA</b> Tells where hazards may occur.</p>	<p><b>HAZARD</b> Tells what the hazard is.</p>	<p><b>SAFEGUARDS</b> Tells how to avoid the hazard.</p>
<p><b>Electrical Equipment</b></p> 	<p><b>Electrical Discharge</b></p> <p>High voltage equipment is utilized in the process. Arcing in the vicinity of flammable or combustible materials may occur. Personnel are exposed to high voltage during operation and maintenance.</p> <p>Protection against inadvertent arcing that may cause a fire or explosion is lost if safety circuits are disabled during operation.</p> <p>Frequent power supply shut-down indicates a problem in the system which requires correction.</p> <p>An electrical arc can ignite coating materials and cause a fire or explosion.</p>	<p>Unless specifically approved for use in hazardous locations, the power supply, control cabinet, and all other electrical equipment must be located outside Class I or II, Division 1 and 2 hazardous areas in accordance with NFPA-33 and EN 50176.</p> <p>Turn the power supply <b>OFF</b> before working on the equipment.</p> <p>Test only in areas free of flammable or combustible material.</p> <p>Testing may require high voltage to be on, but only as instructed.</p> <p>Production should never be done with the safety circuits disabled.</p> <p>Before turning the high voltage on, make sure no objects are within the sparking distance.</p>
<p><b>Toxic Substances</b></p> 	<p><b>Chemical Hazard</b></p> <p>Certain materials may be harmful if inhaled, or if there is contact with the skin.</p>	<p>Follow the requirements of the Safety Data Sheet supplied by coating material manufacturer.</p> <p>Adequate exhaust must be provided to keep the air free of accumulations of toxic materials.</p> <p>Use a mask or respirator whenever there is a chance of inhaling sprayed materials. The mask must be compatible with the material being sprayed and its concentration. Equipment must be as prescribed by an industrial hygienist or safety expert, and be NIOSH approved.</p>
<p><b>Spray Area</b></p> 	<p><b>Explosion Hazard — Incompatible Materials</b></p> <p>Halogenated hydrocarbon solvents for example: methylene chloride and 1,1,1, - Trichloroethane are not chemically compatible with the aluminum that might be used in many system components. The chemical reaction caused by these solvents reacting with aluminum can become violent and lead to an equipment explosion.</p>	<p>Spray applicators require that aluminum inlet fittings be replaced with stainless steel.</p> <p>Aluminum is widely used in other spray application equipment - such as material pumps, regulators, triggering valves, etc. Halogenated hydrocarbon solvents must never be used with aluminum equipment during spraying, flushing, or cleaning. Read the label or data sheet for the material you intend to spray. If in doubt as to whether or not a coating or cleaning material is compatible, contact your coating supplier. Any other type of solvent may be used with aluminum equipment.</p>

# INTRODUCTION

## FEATURES

Features which make the Aerobell 33™ Rotary Atomizer advantageous for use in electrostatic applications include:

- Factory Mutual listed. Limited energy is available to prevent ignition of flammable air/solvent mixtures.
  - Assembly components and bell made of durable plastic material for optimum mechanical strength and solvent resistance.
  - Proven long life turbine motor capable of speeds up to 55k rpm at minimal air consumption. (See "Specifications" in the "Introduction" section of this manual for bell cup speed ratings.)
  - 57mm and 30mm diameter bell assemblies available for application flexibility.
  - Fast color changes are achieved using center feed fluid delivery, integral brake air, high flow regulator and the fluid valves which provide for simultaneous paint push out while solvent washes the feed tube and bell cup.
  - Bell wash is quick and efficient. Solvent usage is controlled at the feed tube with an internally mounted solvent valve.
  - Less waste to the spray booth, with the dump valve located internally next to the feed tube.
  - More precise fluid regulation, with an (optional) internal regulator.
  - Easy to install and maintain. Hosing and connections are easily accessible at either the rear of the assembly or by sliding back the protective rear cover.
  - Quick removal of the turbine assembly for off-line repair.
  - Annular shaping air passage design providing excellent pattern control at minimal air consumption.
  - Aerodynamic design for ease of cleaning external surfaces.
- Assembly can be swiveled to provide oblique spray angles for better paint coverage in difficult areas of the product.
  - Turbine air exhausts behind bell, keeping paint and solvent contamination out of atomizer interior and keeping back of bell clean.
  - Speed readout (or control) uses reliable magnetic pickup for fiber-optic transmission of rotational speed data.

## GENERAL DESCRIPTION

### Aerobell 33 System

The Ransburg Aerobell 33 is a high speed rotary atomizer system designed to meet agency safety requirements for safer operation. This system is incapable of releasing sufficient electrical or thermal energy during normal operating conditions to cause ignition of specific hazardous materials in their most easily ignited concentrations in air (See NFPA-33 Regulations). The Aerobell 33 provides electrostatic application with excellent atomization and transfer efficiency for a wide variety of coating materials.



### WARNING

- The Aerobell 33 System is designed to provide safer operation in accordance with NFPA-33, when used and maintained in a proper manner. Equipment cleanliness and proper routine maintenance are required to maintain safe operating conditions.

### Bell Assembly

This plastic bell cup is coated with a proprietary resistance material for transfer of electrostatic charge to the atomized fluid. Two different sized bell cups are available: 30mm and 57mm. Each bell cup size has a matching shroud and shaping air ring. (See Table "A", Figure 16.)

### Air Turbine Assembly

The air bearing turbine assembly with bell cup is mounted to the air manifold assembly with four socket head cap screws. The front resistor tube is also attached to the air turbine assembly and provides the high voltage connection to the motor shaft and bell.

### Air and Fluid Manifold Assembly

This unit mounts onto the insulator support rod assembly with a swivel post. The fluid valve manifold block is mounted directly onto the back side, connecting with fluid passages internal to the manifold. Tube connections for valve control lines protrude through the rear shroud plate. The fluid feed tube is screwed into the rear of this manifold block and the air turbine assembly mounts to the front with four socket head screws.

### Insulator Support Rod Assembly

The air and fluid manifold assembly mount onto the insulator support rod assembly, which in turn is attached to the reciprocator or support stand.

### Rear Shroud Assembly

The rear shroud assembly consists of a rear bulkhead which provides a passageway for fluid and air tubes, mounting rods to connect the rear bulkhead to the air and fluid manifold assembly, a fluid regulator mounted onto the outside surface of the rear bulkhead, and a resistor module nested between the rear bulkhead and air manifold assembly.

### Resistor Module

The module encapsulates the high voltage resistors necessary for control of the electrostatic charge being fed to the bell through the high voltage cable.

### Power Supply and Junction Tank

The Aerobell 33 System operates with a variety of high voltage power supplies. The power supplies operate at output voltages of up to 100,000 volts DC. Also available is a junction tank which is used to distribute high voltage to multiple Aerobell 33 assemblies from a single power supply.



## WARNING

- The high voltage equipment that is used in this application creates a hazard for personnel. The high voltage power supply is not approved for use inside of the spray booth, as defined in NFPA-33. This high voltage power supply can produce sparks which are capable of igniting coating material.

## NOTE

- The Aerobell 33 atomizer assembly includes an internal resistor module and resistor tube in series which provides appropriate current limiting at the atomizer. The resistance coating on the outer surface of the bell not only transfers the high voltage to the bell edge, but also helps to control the discharge energy at the bell edge to achieve safe operation.

### High Voltage Cables

The SSW-1064 high voltage cable is used to connect the power supply to the resistor module inside the atomizer assembly.

### Speed Monitor/Control

The Aerobell 33 rotary atomizer is designed to operate with the Ransburg PulseTrack™ or Atomizer Module for speed monitoring and/or speed control.

## SPECIFICATIONS

### Electrical

<b>Power Supply</b>	LECU5003 /LEPS5001
<b>Type:</b>	(Voltage Master™) 76045 / LEPS5002 (MicroPak™)
<b>Charging Method:</b>	Direct
<b>Output Voltage:</b>	30-100 kV Variable
<b>Output Current:</b>	125 µA (Short Circuit)
<b>Turbine Speed Control:</b>	PulseTrack or Eurocard Atomizer Module
<b>Paint Resistance:*</b>	.1 MΩ to ∞
<b>Part Sprayability:</b>	Determine sprayability of part to be coated using 76652-02 or 76652-04, Test Equipment (See TE-98-01).

\*(Use Kit No. 76652-03 or 76652-04, Test Equipment)

### Mechanical

<b>Length:</b>	16.5 inches (419mm)
<b>Diameter:</b>	5.6 inches (142mm)
<b>Approximate Weight:</b>	10.3 lbs. (4.7 kg)
<b>Turbine Type:</b>	Air Bearing Impulse Drive
<b>Turbine Air Supply:</b>	Variable (See Figures 1-4)
<b>At 30,000 rpm</b>	23 psig (158 kPa)
<b>(Nominal):</b>	7.7 scfm (220 slpm)
<b>Maximum Turbine Speed:</b>	Continuous (Intermittent)
<b>30mm Bell Cup:</b>	40,000 rpm (55,000 rpm)
<b>57mm Bell Cup:</b>	40,000 rpm (55,000 rpm)
<b>Bearing Air Supply:</b>	(See Figure 6)
<b>(Nominal)</b>	90 psig (±10 psi) (621 kPa ±69 kPa) 2.1 scfm (60 slpm)
<b>Shaping Air Supply:</b>	Variable (See Figure 5)
<b>(Nominal)</b>	5-15 psig (34-103 kPa) 4.7-9.8 scfm (134-280 slpm)
<b>Brake Air Supply (Nominal):</b>	60 psig (414 kPa)
<b>Maximum Fluid Pressure Supply:</b>	100 psig (689 kPa)
<b>Fluid Flow Rate:</b>	25-500 cc/minute
<b>Usable Spray Pattern Diameter:</b>	15-30 inches (381-762 mm)
<b>Bell Cup Cleaning Time:</b>	Approximately 2-3 sec.
<b>Color Change Time:</b>	Dependent on system configuration, fluid pressure, fluid viscosity, fluid line lengths, etc.
<b>Speed Readout:</b>	Magnetic pickup, unidirectional fiber-optic transmission
<b>Atomizer Replacement Time:</b>	Less than 2 minutes
<b>Bell Cup Replacement Time:</b>	Less than 2 minutes

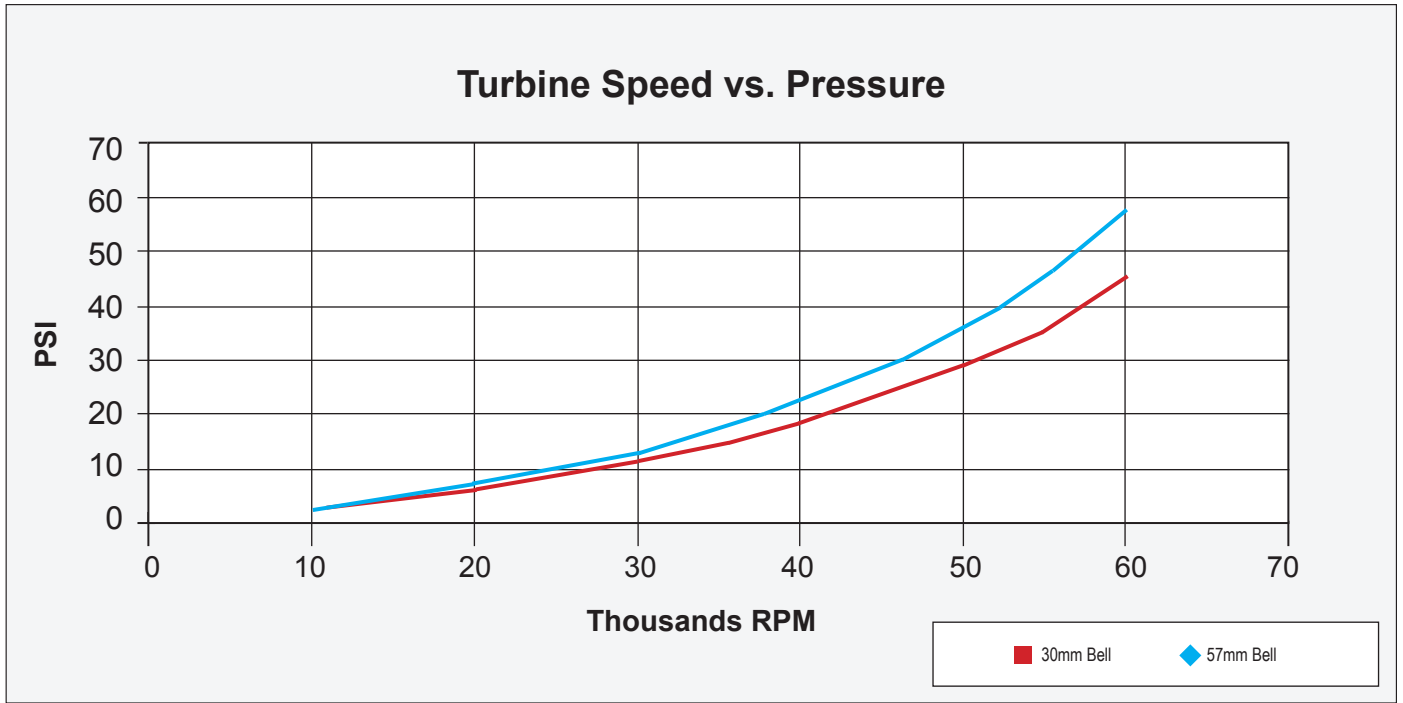

Figure 1: Turbine Speed vs. Pressure

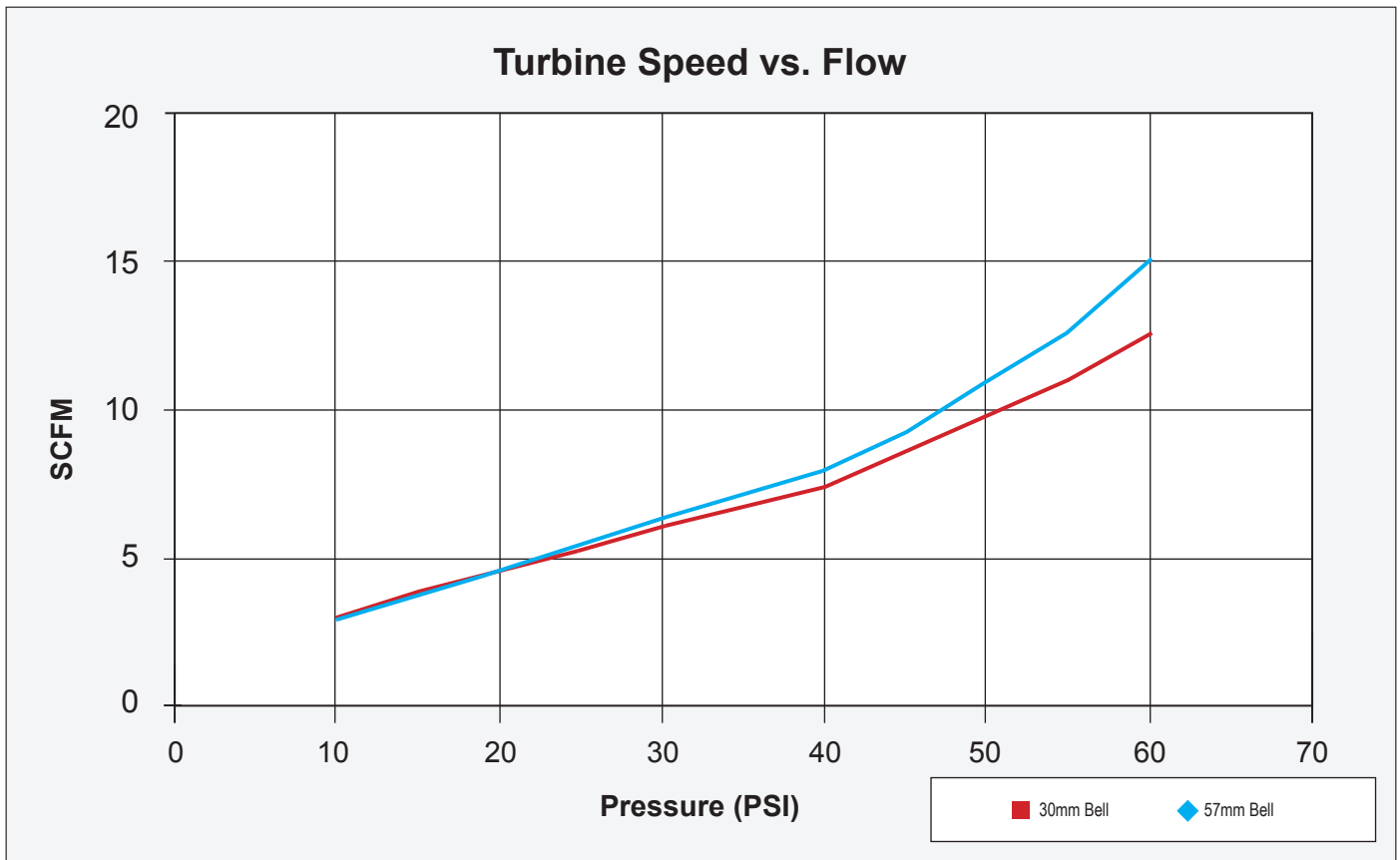

Figure 2: Turbine Speed vs. Flow

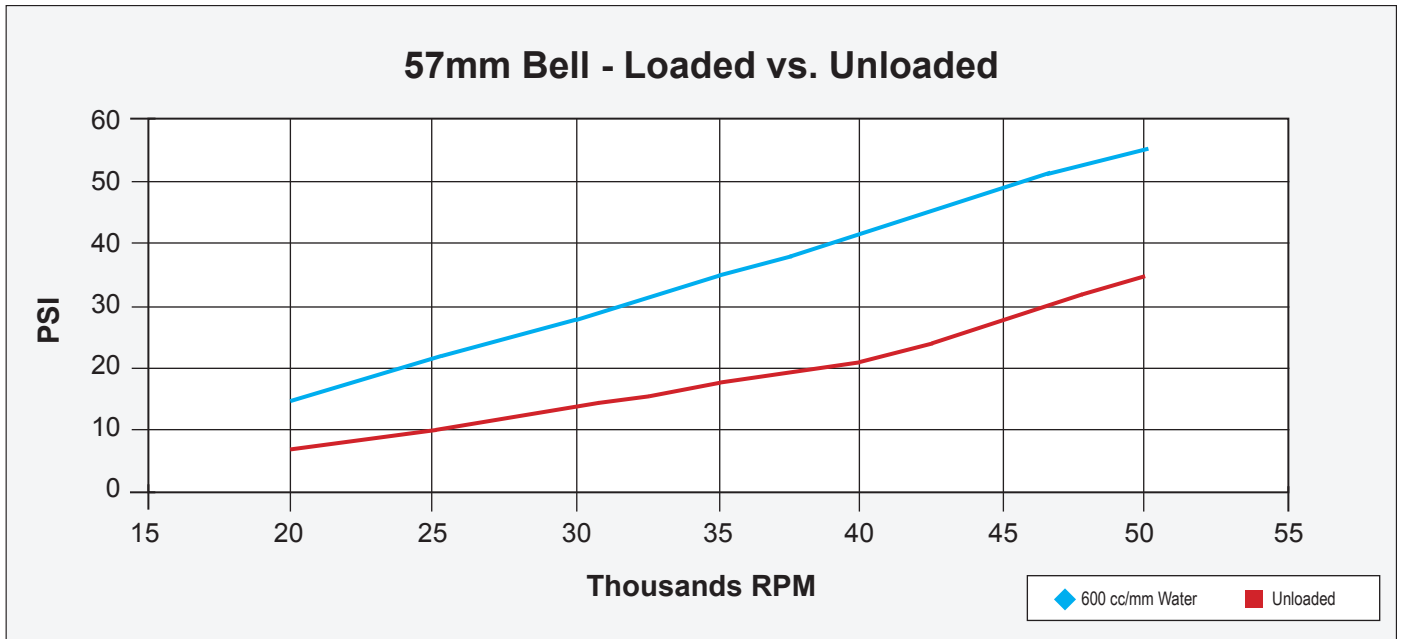

Figure 3: 57mm Bell / Loaded vs. Unloaded

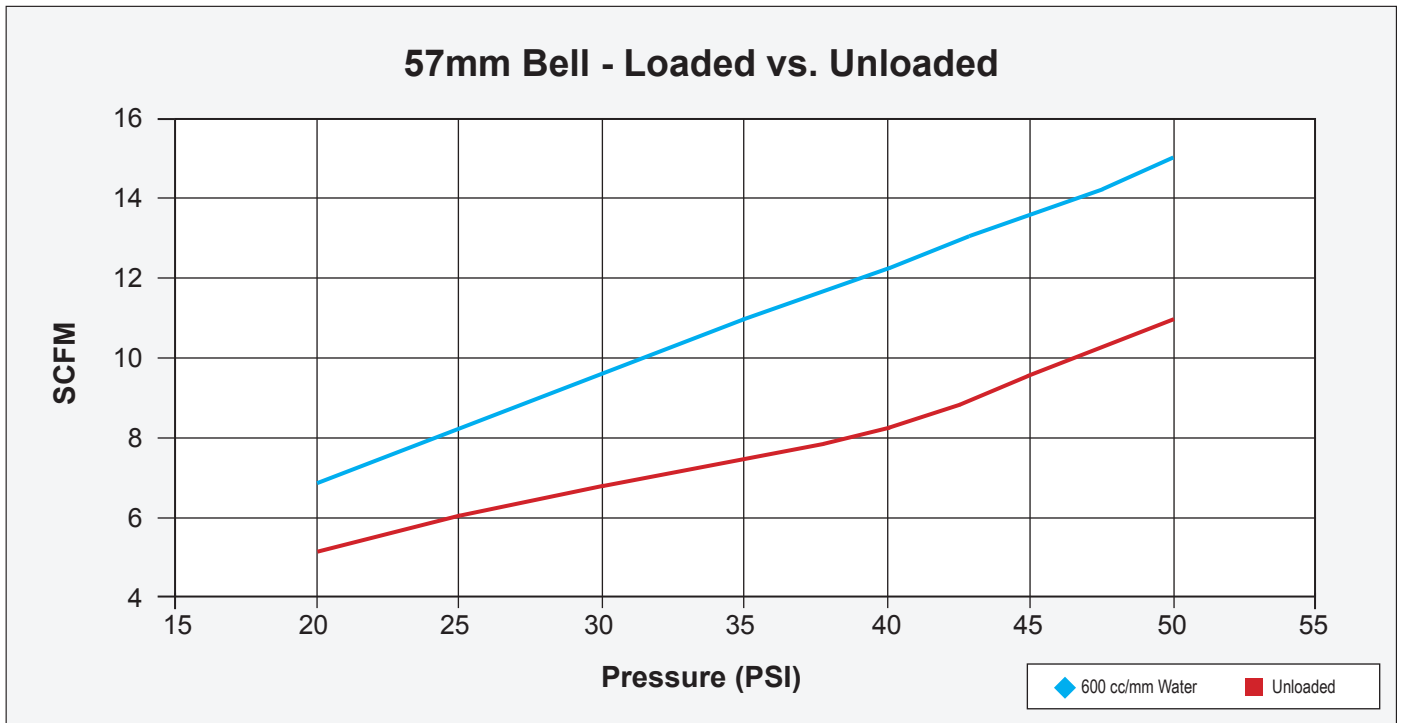

Figure 4: 57mm Bell / Loaded vs. Unloaded

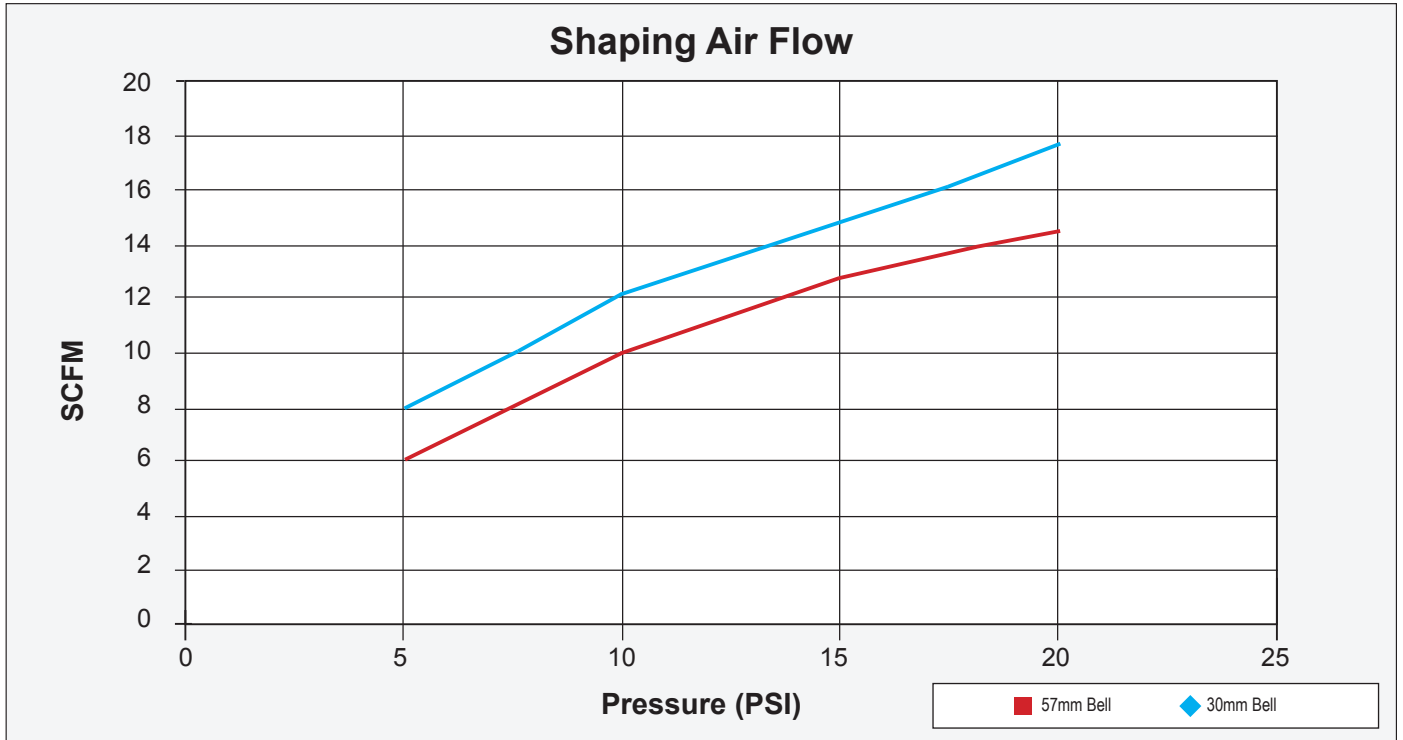

Figure 5: Shaping Air Flow

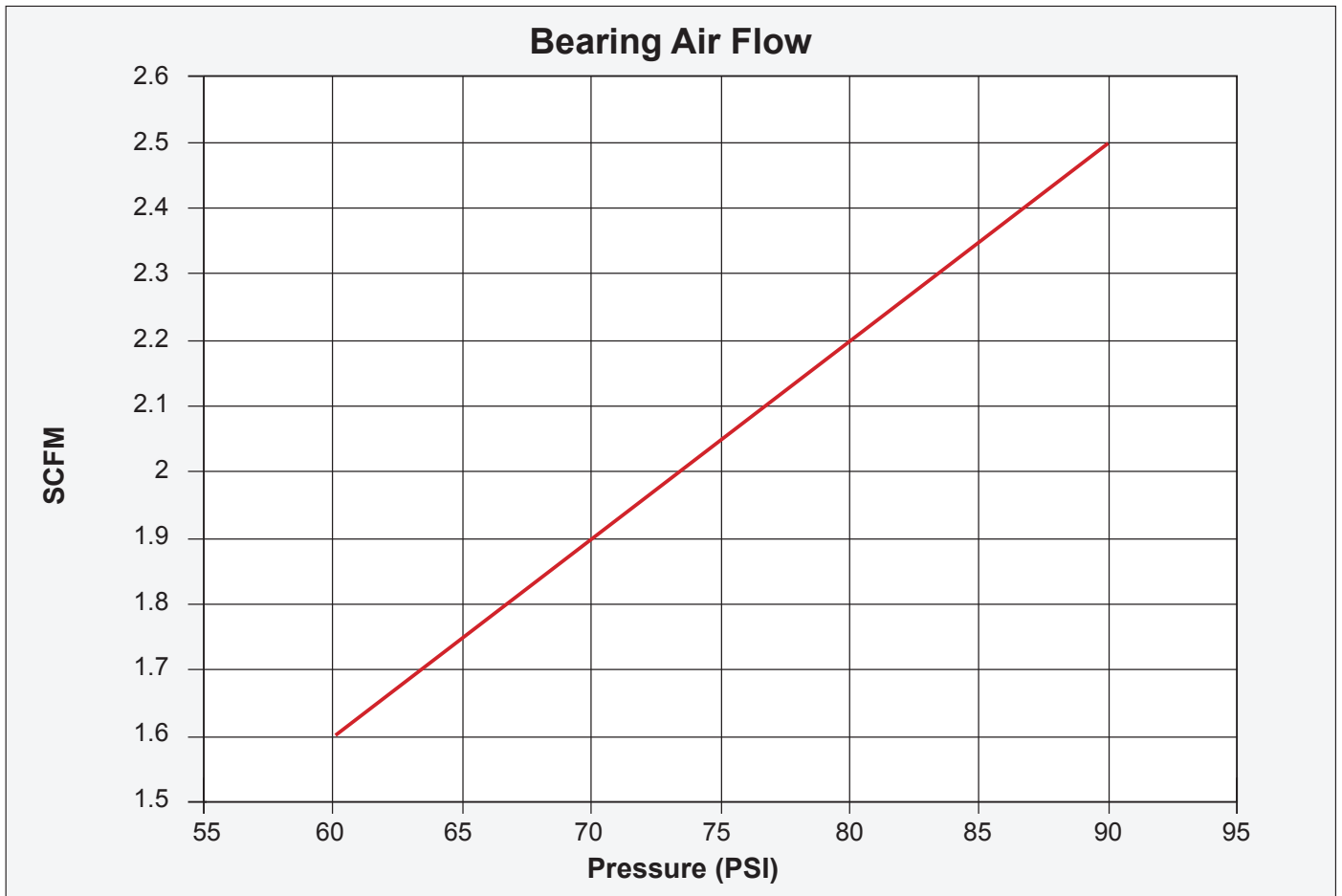

Figure 6: Bearing Air Flow

# INSTALLATION

## AIR FILTER INSTALLATION

The following air filter installation guidelines are essential for optimum performance.

1. Use only recommended pre-filters and bearing air filters as shown in Figure 8. Additional system air filtration (i.e., refrigerated air dryer) may also be used if desired.
2. Mount the bearing air filter as close as possible to the Aerobell 33. (Do not mount further than 30 feet (9m) away.)
3. Do not use tape, pipe dope, or other thread sealant downstream of the bearing air filter. Loose flakes of tape or other sealant can break loose and plug the very fine air holes in the turbine air bearings.
4. If air heaters are used in the system (to minimize the effect of excessively humid conditions), and the heated air will exceed 120°F, the heaters must be located after all filters to prevent damage to the filter media.

AIR PRESSURE REQUIREMENTS		
	Tube Size	Air Pressure Requirements
Bearing Air Supply (B.A.)	1/4" O.D.	90 psi ±10 (621kPa ± 69kPa)
Bearing Air Return (B.A.)	1/4" O.D.	80 psi ±10 (551kPa ± 69kPa)
Turbine Air (T.A.)	1/2" O.D.	Variable
Shaping Air (S.A.)	3/8" O.D.	Variable
Brake Air (BRK) (if used)	3/8" O.D.	60 psi ±10 (413kPa ± 69kPa)
Trigger Valve Control (TV)	1/4" O.D.	80 psi ±10 (551kPa ± 69kPa)
Dump Valve Control (PD)	1/4" O.D.	80 psi ±10 (551kPa ± 69kPa)
Solvent Valve Control (SV)	1/4" O.D.	80 psi ±10 (551kPa ± 69kPa)
<b>Paint Fluid Regulator (Optional):</b>		
High Flow Signal Air (High)	1/4" O.D.	Variable 70 psi max. (482 kPa)
Low Flow Signal Air (Low)	1/4" O.D.	Variable 80 psi max. (551 kPa)

Figure 7: Air Tubing Connections

AIR FILTRATION REQUIREMENTS		
Filter Model #	Description / Specifications	Replacement Element Part #
HAF-503	Pre-filter, removes coarse amounts of oil, moisture & dirt. Used upstream of RPM-417 pre-filter (used in systems with poor air quality).	HAF-15 Element, One
RPM-417	Pre-filter, coalescing type, 136 scfm, 98.5% efficiency particulate removal .3 to .6 micron, max. aerosol passed 1.0 micron, max. solid passed .4 micron (dependent upon scfm requirement per applicator, one RPM-417 can be used with up to three Aerobell 33 assemblies).	RPM-32 Elements, Carton of 4
RPM-418	Bearing air filter, coalescing type, 19 scfm, 99.995% efficiency particulate removal .3 to .6 micron, max. aerosol passed .6 micron, max. solid passed .2 micron (one per applicator).	RPM-33 Elements, Carton of 8

Figure 8: Recommended Air Filtration



**⚠ CAUTION**

- Air must be properly filtered to ensure extended turbine life and to prevent contamination of the paint finish. Air which is not adequately filtered will foul the turbine air bearings and cause turbine failure. The correct type of filters must be used in an Aerobell 33 system. The filter elements must be replaced on a regular schedule to assure clean air.
- **It is the user's responsibility to ensure clean air at all times. Turbine failure resulting from contaminated air will not be covered under warranty.** Figure 8 shows the pre-filter and bearing air filter(s) which are recommended for use in Aerobell 33 systems. If other filters are incorporated in the system, the filters to be used must have filtering capacities equal to or better than those shown in Figure 8.
- The user must ensure the bearing air supply is not inadvertently turned off while the Aerobell 33 air motor is turning. This will cause air bearing failure.

**FLUID CONNECTIONS**

	Fixed Atomizer	Pressure (nominal/max.)
Paint Line (P.IN)	.156", .170", or .188" I.D. PFA	100 psig (689 kPa)
Solvent Line (SOL)	.125" I.D. PFA	30-60 psig (207-413 kPa)
Dump Line (DUMP)	.250" I.D. PFA	Variable

Figure 9: Fluid Tubing Connection Requirements

**⚠ CAUTION**

- The normal fluid flow range is 25-500 cc/min. The maximum flow rate must not exceed 500 cc/min. to avoid solvent or paint from flooding into the internal portion of the air bearing motor assembly or front shroud.

**MOUNTING**

The Aerobell 33 incorporates its own insulator mounting rod. The diameter at the rear is 1.9 inches (48.3mm), for mounting to a reciprocator, stationary stand, or other means of support. The atomizer assembly is mounted to this horizontal rod by a 3/4 inch (19.1mm) insulating post, inserted into a swivel clamp and secured by four plastic bolts. The arrangement allows positioning of the front of the turbine. Normally, the insulator support rod is positioned perpendicular to the conveyor path, with the swivel providing for left or right adjustment of the atomizer assembly. The swivel clamp plate can be inverted to provide a locking mechanism to hold the applicator in line with the insulator support rod.

**FLUID CONNECTIONS**

The paint supply to the Aerobell 33 is connected at the rear of the atomizer assembly to the regulator. Solvent and dump line connections enter the housing and are connected to the appropriate valves. Ports are labeled with blue lettering.

**ELECTRICAL CONNECTIONS**

Electrical connections to the Aerobell 33 atomizer assembly consist of only the high voltage cable. This cable plugs into the resistor module fitting, located at the rear of the assembly, which protrudes through an opening in the rear bulkhead. After inserting the cable entirely into the tube and feeling the banana plug make contact on the inside, tighten the cable compression fitting nut around the high voltage cable with an appropriate wrench. Reinstall the connector cover with plastic screw.

**SPEED MONITOR CONNECTIONS**

A fiber-optic cable assembly connects the speed signal output of the rotary atomizer assembly to the Pulsetrak Speed Monitor/Control System or Fotronics™™ Atomizer Module.

## INTERLOCKS

The following system interlocks are required to prevent equipment damage:

1. Bearing air should remain on at all times and should be shut off only by turning off the main air to the pneumatic control cabinet.

### CAUTION

- When the turbine air is turned off, the turbine will continue to operate or “coast down” for about two minutes. Provisions should be made to assure that the operator waits at least three minutes, after shutting off the turbine air, before shutting off the main air supply.
- The bell assembly must be removed when making flow checks. If the paint is turned on when the bell is mounted on the motor shaft and not rotating, paint will enter the shaft and possibly damage the air bearing. Normally pneumatic interlocks will not allow the paint to trigger on when the turbine air is off.

### WARNING

- The high voltage and/or coating material must never be turned on unless the bell cup is mounted on the motor shaft and the turbine is rotating.
  - Pneumatic input to the turbine air inlet must be controlled to prevent the turbine from exceeding the maximum rated intermittent speed of 55,000 rpm. (See “Specifications” in the “Introduction” section.)
2. It should not be possible for the coating material to be sprayed unless the turbine is spinning.
  3. Two interconnected bearing air ports are provided, one for supply air and the other to be used as a return signal for measuring bearing air pressure at the atomizer. If bearing air falls below 60 psi at the atomizer, the turbine air should be automatically interlocked to shut off.
  4. High voltage must be interlocked with the solvent valve pilot signal to prevent solvent flow while high voltage is energized.
  5. Turbine air and brake air must be interlocked to prevent both from being used simultaneously.

# OPERATION

## WARNING

- Operators must be fully trained in safe operation of electrostatic equipment. Operators must read all instructions and safety precautions prior to using this equipment (See NFPA 33, Chapter 16).

As with any spray finishing system, operation of the Aerobell 33 involves properly setting the operating parameters to obtain the best finish quality for the coating material being sprayed, while maintaining correct operation and reliability of the equipment used. Adjustments to operating parameters, which cover spraying, cleaning and on/off control, include:

- Coating Materials
- Fluid Flow Rate Control
- Fluid Valve Control
- Turbine Speed
- Bearing Air Adjustment
- Shaping Air
- Brake Air
- Electrostatic Voltage
- Target Distance

## COATING MATERIALS

The Aerobell 33 can be used with a full range of coating material conductivities. However, with coatings having very high conductivities, such as waterborne paints, it may be necessary to isolate paint supply from ground.

## WARNING

- Electrical discharge of a high electrical capacitance fluid/paint system can cause fire or explosion with some materials. If arcing occurs when a specific coating materials is used, turn the system off and verify that the fluid is non-flammable. In these conditions the system is capable of releasing sufficient electrical and thermal energy to cause ignition of specific hazardous material in air.

## FLUID FLOW RATE CONTROL

Fluid flow is controlled by an internally mounted dual diaphragm fluid regulator. Reference the LREG5001, DR-1™ Plastic Fluid Regulator, Manual (latest version) for detailed information.

The regulator features two independently controllable flow pressure ranges from the fluid output port. The high flow range port accommodates higher fluid deliveries thereby providing increased film build capabilities and minimal color change times. The low flow range provides precise fluid delivery control. There are seven low range models available (1:1, 1:2, 1:3, 1:4, 1:6, 1:8, and 1:10) which can be selected based on the required fluid flow rate.

Separate pilot signals modulate each of the regulator's two diaphragms to control the amount of paint being delivered from the regulator to the atomizer bell cup. These pilot signals can be controlled manually or automatically with closed loop flow control system.

Because of the regulator's dual range capabilities, it provides the user flexibility of selecting either the high flow range or the low flow range. Different coating material viscosities and quick color change requirements may necessitate the use of both ranges. If color change time is not a factor or if material viscosity remains relatively constant, either port may be used depending on flow rate requirements.

The high flow port characteristics are similar to those found in most commercially available, air operated fluid regulators. Fluid regulation from the high flow port is therefore comparable in total flow capacity, although consistency of flow is improved considerably when using a regulator. All regulators, regardless of ratio designation, have the high flow port.

The low flow (i.e. 1:2, 1:4, etc.) port provides a lower, more precise flow response curve. Fluid output, as a result, is less likely to be affected by pilot signal errors. An increase in the ratio (i.e. from 1:2 to 1:4) provides a lower slope, but, more precise response curve. This same increase in ratio, however, will reduce flow capacity and should be considered when selecting the proper regulator ratio.

The following factors must then be considered when selecting the regulator ratio required for proper fluid control:

- Maximum fluid output requirements (Guide: 10 psi (69 kPa) minimum, 30 psi (206 kPa) max.)
- Fluid tubing inside diameter (ID) and length
- Fluid feed tube inside diameter (ID) and length
- Fluid viscosity
- Fluid input pressures (Guide: 10 psi (69 kPa) above max. fluid output pressure)

Only proper testing will determine which regulator ratio should be used. If conditions change after installation which require a different low flow ratio, this regulator can be altered easily by replacing the existing ratio spacer ring and upper retainer with the desired ratio (ratio designation is etched on the side of the spacer ring).

The output of the regulator is externally connected to a fitting on the fluid manifold assembly. The fluid manifold assembly is equipped with valves which are pneumatically operated to direct the flow of paint to either the feed tube or dump line and to supply a intermittent solvent bell wash for the feed tube and bell cup.

The feed tube is available in several sizes (See Figure 11). The viscosity and volume of the coating material being sprayed determine the correct size of feed tube for each installation. The feed tube diameter acts as a linear restrictor to create back pressure on the fluid regulator so that it can provide accurate and repeatable flow to air signal resolution.

**Fluid Flow Rate Check**

In test mode, the flow rate can be measured by removing the bell cup from the atomizer, turning the fluid flow on and capturing the material in a graduated beaker or measuring cup for a fixed period of time (shaping air, high voltage and turbine air must be off).

 **WARNING**

► Danger of shock and/or personal injury can occur. Proper grounding procedures must be followed. Personnel must never work around the turbine when the turbine is spinning or when high voltage is turned on.

Low Flow Rates	Fixed Atomizer Regulator Part No.
1:1	LREG5001-01
1:2	LREG5001-02
1:3	LREG5001-03
1:4	LREG5001-04
1:6	LREG5001-06
1:8	LREG5001-08
1:10	LREG5001-10

Figure 10: Fluid Regulator Selections

Orifice Size	Part No.
.041 I.D.	76416-04
.061 I.D.	76416-06
.093 I.D.	76416-09
.125 I.D.	76416-12

Figure 11: Fluid Tube Selections

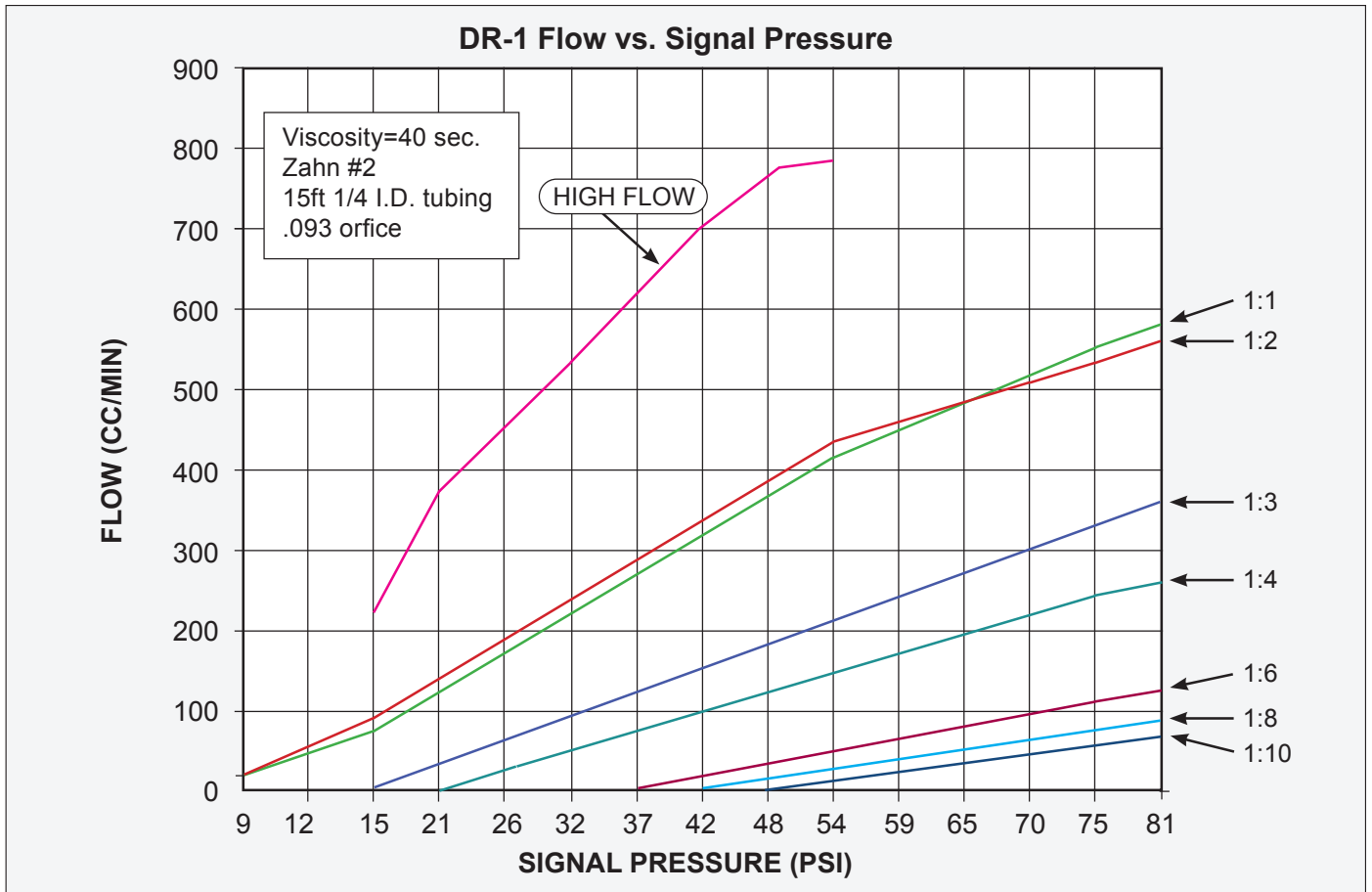

Figure 12a: DR-1 Flow Vs. Signal Pressure

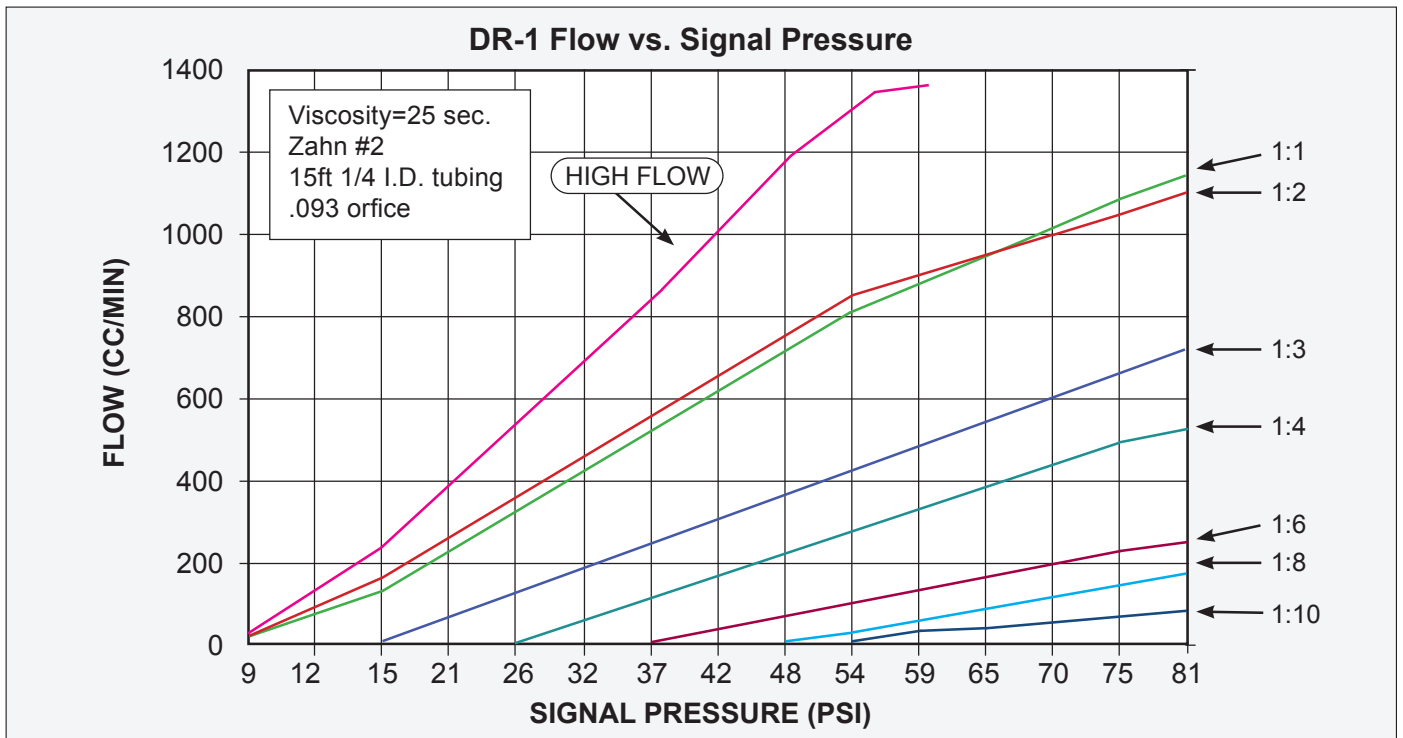

Figure 12b: DR-1 Flow Vs. Signal Pressure

## FLUID VALVE CONTROL

### (Trigger, Dump & Solvent)

The fluid valves in the Aerobell 33 are actuated by an air signal. The air pressure must exceed 70 psi to assure proper actuation of the valve. Applying air to the valve actuator turns on the fluid flow for that valve.

The trigger valve controls the paint flow to the bell. When actuated, paint flows through the valve to the fluid tube, and into the rear of the bell cup. The bell must be spinning at least 10,000 rpm when fluid is turned on to enable the fluid to flow through the bell paint passage holes and be atomized.

The dump valve controls the paint flow through the dump line. When actuated, paint flow is directed to the dump return line. This provides a method of rapidly removing paint from the incoming line for cleaning and/or color change. Normally, the dump valve is not actuated at the same time as the paint trigger valve since the trigger valve is intended to cause the fluid to flow to the bell at the prescribed input pressure.

The solvent valve controls the flow of cleaning solvent to the bell. When actuated, solvent flows through the manifold and fluid tube and into the rear of the bell cup. This provides cleaning of the inside of the bell cup. The solvent valve is not triggered at the same time as the paint trigger valve to prevent solvent from flowing backward into the paint line.

### CAUTION

- The normal fluid flow range is 25-500 cc/minute. During a color change or when flushing the system, higher flow rates may be required. However, the maximum flow rate must not exceed 500 cc/minute to avoid solvent or paint from flooding into the internal portion of the air bearing motor assembly or front shroud.
- High voltage must be interlocked with the solvent valve to prevent solvent spraying while high voltage is on.

### WARNING

- When flushing the Aerobell 33, always flush through the **dump valve** rather than the trigger valve. Only use solvent to flush the fluid tube in the bell. A solvent/air mixture or sequence will cause paint build-up on the fluid tube.

## TURBINE SPEED

Turbine speed is determined by the input pressure at the rear of the atomizer.

Turbine speed is intended to be closed loop controlled using the fiber-optic speed transmitter, located on the turbine manifold. A speed input to a remote speed controller, such as the Atomizer Module, is recommended.

### NOTE

- The bell rotational speed determines the quality of atomization and can be varied for various paint flow rates and paint formulations. For optimum transfer efficiency and spray pattern control, the bell rotational speed should be set at the minimum required to achieve proper atomization. **Excessive speed reduces transfer efficiency!**

### WARNING

- Do not exceed the maximum rated intermittent operating speed and turbine inlet pressure (55,000 rpm at approximately 60 psi for the 57mm bell or 55,000 rpm at approximately 45 psi for the 30mm bell). Excessive speed may cause air turbine damage or damage to the bell.

## BEARING AIR ADJUSTMENT

The nominal bearing air pressure is 90 psi (620 kPa), measured at the rear of the atomizer. Minimum 80psi (552 kPa) pressure is 80 psi (552kPa) and maximum pressure is 100 psi (689 kPa). The turbine should never be operated with less than 80psi (552kPa) bearing air pressure.

Bearing air must be present when turning the turbine on. Bearing air must remain on when the turbine air is turned off until the turbine stops spinning. Never turn off bearing air to cause the turbine to stop spinning. If connected, brake air can be used to slow the turbine.

**⚠ CAUTION**

➤ Bearing air must be on whenever the turbine is operated. If not, severe bearing damage will occur. It is recommended that bearing air be left turned on at all times, except during maintenance or disassembly.

Bearing damage (and subsequent turbine failure) caused by running the turbine without bearing air will not be covered under the Ransburg warranty.

The Aerobell 33 is equipped with a bearing air return line to monitor bearing air pressure at the turbine manifold. When connected to the remote Atomizer speed controller, operation of the turbine will automatically be shut down whenever the bearing air pressure falls below 60 psi (414 kPa).

## SHAPING AIR

Shaping air is used to shape the spray pattern. Lower input pressure results in wider pattern size, while higher input pressure reduces the pattern size. Shaping air does not help atomize the material, but will assist in the penetration of atomized particles into cavity areas. Ideally, shaping air should be kept at the minimum pressure which will provide a proper finish for the fluid being sprayed. Excessive shaping air will cause some atomized particles to blow by the target, reducing the wrap around effect at edges and corners. Excessive shaping air may also cause some paint particles to bounce back onto the atomizer, causing the atomizer surface to become contaminated.

## BRAKE AIR

Brake air is used to slow the turbine speed in a minimum length of time. It is advantageous for short cycle times during color change, or may be used to reduce speed or stop the turbine. Never operate brake air with the turbine air on. Approximate brake times to reduce the turbine speed are shown in Figure 13. These times are based on 60 psi (414 kPa) air pressure at the brake air connector.

The use of brake air is optional, and may not be required for many installations. The Atomizer Module control system provides the circuitry for automatic use of the brake air.

## BRAKING TIME

To Brake From (RPM)	Seconds (Approx.)
50,000 to 40,000	3.7
50,000 to 20,000	7.5
50,000 to 0	10.0
40,000 to 20,000	4.0
40,000 to 0	9.0

Figure 13: Braking Time

## ELECTROSTATIC VOLTAGE

The Aerobell 33 Rotary Atomizer receives its operating voltage through a high voltage cable that is connected to a remote power supply. The power supply model and high voltage setting will depend upon various application requirements. See the "Specifications" section of this manual for approved power supplies and refer to that manual for detailed operating instructions.

### NOTE

➤ If paint defects occur, such as fatty edges or picture framing, reducing the voltage should be a **last** resort. To correct the problem, adjustments to paint resistivity or lead and lag trigger adjustments should be made.

The electrostatic voltage applied to the Aerobell 33 will affect pattern size, transfer efficiency, wrap, and penetration into cavity areas. Normally 100 kV setting is appropriate for most applications.

## TARGET DISTANCE

The distance between the Aerobell 33 atomizer and the target will affect the finish quality and efficiency. Closer distances give a smaller pattern, wetter finish and greater efficiency. Greater distance will provide a larger pattern size and drier finish. The high voltage circuitry will enable the applicator bell to be operated to within a few inches of the target without adjusting the voltage setting. The recommended target distance is 8 to 12 inches (200-300mm).

# MAINTENANCE

## CLEANING PROCEDURES

### WARNING

- Electrical shock and fire hazards can exist during maintenance. High voltage supply must be turned off before entering the spray area and performing any maintenance procedures on the atomizer. Spray booth fans should remain on while cleaning with solvents.
- Never touch the atomizer bell while it is spinning. The front edge of the bell can easily cut into human skin or cut through gloves and other materials. Be sure the atomizer bell has stopped spinning before attempting to touch it. Approximate time for the bell to stop spinning after turning off turbine drive air is three minutes.

In addition to the above "Warning", which relates to potential safety hazards, the following information must be observed to prevent damage to the equipment.

### CAUTION

- Do **not** immerse the Aerobell 33 turbine in solvent or other liquids. Turbine components will be damaged.
- Bearing air must be on during all cleaning procedures to protect the air bearing components.

### Internal Fluid Path Cleaning

Cleaning the incoming paint line (from paint supply source such as color manifold through the fluid valve block and bell assembly):

Turn off high voltage and turn on the trigger valve. With the bell spinning, flush cleaning solvent through the incoming paint line and through the manifold passages, through the fluid tube and onto the bell. The spinning bell will atomize the solvent and clean out the bell passages. If desired, open the dump valve to flush through the dump line for a faster and contained system flush.

### Internal Fluid Path Cleaning (Without Cleaning the Incoming Paint Line)

Turn off the high voltage and trigger valve. With the bell spinning, turn on the solvent valve to allow cleaning solvent to flow through the manifold passages, through the fluid tube, and onto the bell. The spinning bell will atomize the solvent and clean out the bell passages.

With the solvent valve open, open the dump valve to clean the remaining manifold fluid passage and to flush the dump line if desired.

### CAUTION

- The maximum flow rate of 500 cc/minute must not be exceeded during a flush routine.

### External Atomizer Surface Cleaning

- Verify that the high voltage is turned off.
- All external surfaces may be cleaned using a mild solvent and lint free rags to hand wipe the Aerobell 33. Turbine drive air must be off, but leave shaping air and bearing air on. Be careful not to drip solvent into the opening behind the bell.
- If conductive, polar solvents are used to clean the Aerobell 33 unit, all residue must be removed using a non-conductive non-polar solvent (ex., high flash naphtha).
- Do not spray the Aerobell 33 unit with a solvent gun used for cleaning. The cleaning fluid under pressure may aid conductive materials to wick into hard to clean areas or may allow fluids to be forced into the turbine assembly.
- Do not reuse an atomizer bell that shows signs of damage such as nicks, heavy scratches, dents, or excessive wear.



**⚠ WARNING**

- **NEVER** wrap the applicator, associated valves and tubing, and supporting hardware in plastic to keep it clean. A surface charge may build up on the plastic surface and discharge to the nearest grounded object. Efficiency of the applicator will also be reduced and damage or failure of the applicator components may occur. **WRAPPING THESE COMPONENTS IN PLASTIC WILL VOID WARRANTY.**

**⚠ WARNING**

- To reduce the risk of fire or explosion, OSHA and NFPA 33 require that solvents used for exterior cleaning, including bell cleaning and soaking, be nonflammable (flash points higher than 100°F/37.8°C). Since electrostatic equipment is involved, these solvents should also be non-polar. Examples of non-flammable, non-polar solvents for cleaning are: Amyl acetate, methyl amyl acetate, high flash naphtha and mineral spirits.
- Do not use conductive solvents such as MEK to clean the external surfaces of the Aerobell 33.
- When using a rag to hand wipe the Aerobell 33, the turbine air should be off but leave the shaping air and bearing air turned on. Ensure the rotation has come to a complete stop. Be careful not to drip solvent into the opening behind the bell.

**Bell Cleaning**

Normally, the internal cleaning instructions will suffice to clean the bell. If the internal cleaning instructions do not sufficiently remove all paint and residue from the bell, the bell may be removed for hand cleaning.

**NOTE**

- It may be advantageous to develop a maintenance schedule for hand cleaning and inspection of the atomizer bell cup. (See Service Literature “IL-304” in the “Appendix” section of this manual.)

Inspection of the bell semiconductive coating is required to determine if wear or flaking has occurred. Excessive loss of bell coating can cause poor transfer efficiency and paint wrap back onto the atomizer.

Clean the bell by soaking in an appropriate solvent to soften paint residue. Do not soak for more than a 24 hour period. Use a soft cloth to remove the paint and a soft tool like a toothpick to clean the paint holes. Be sure that all signs of paint are removed. Rinse and dry the bell.

**⚠ WARNING**

- Do not attempt to clean the bell edge while the bell is rotating. When attempting to stop or slow down the bell cup, **do not** hold a rag or gloved hand against the bell edge. This could damage the bell edge, which would adversely affect transfer efficiency and coating quality.

**⚠ CAUTION**

- Do not use abrasive materials which will scratch or damage the plastic bell, or which will scratch the semiconductive coating on the surface of the bell.
- Before reinstalling the bell onto the shaft, check and clean the tapered mating surfaces of the turbine shaft and bell for any paint residue.

Using an atomizer bell with paint buildup may cause a bell imbalance. An imbalanced bell may cause bearing damage and turbine failure, or may create mechanical stress on the plastic bell when operating at high speeds. Excessive paint residue caught between the internal tapered surface which seats in the motor shaft can prevent the bell from seating properly and result in an unbalanced turbine condition.

**⚠ CAUTION**

- Care must be taken when mounting the bell assembly onto the motor shaft. The bell should turn on freely for several turns or until it fully bottoms on the motor shaft. If resistance is felt when the bell is first being turned onto the shaft, do not proceed further, the bell may be cross-threaded on the shaft. Remove the cup and carefully reinstall. If it is still difficult to turn, replace the bell.

**⚠ WARNING**

- A bell assembly that is cross-threaded on the shaft can damage the bell, motor or shaping air housing and may come off the shaft while rotating.

## VIBRATION NOISE

If the Aerobell 33 is vibrating or making an unusually loud noise, it may mean that there is an unbalanced situation. The bell assembly may have dried paint on it, the bell may be physically damaged, or there may be paint trapped between the bell and shaft preventing the bell from properly seating. If any of these conditions exist, they must be corrected prior to further operation. Do not continue to operate a noisy turbine. Warranty does not cover failure caused by imbalanced loading conditions.

### WARNING

- If a bell cup comes off a rotating shaft because of motor seizing or any other reason, the bell must be returned to Ransburg for inspection and evaluation to determine if the bell can be used in operation.

## TURBINE REPAIR & REBUILD

Turbine field repair or rebuild only after factory warranty expires. Any attempt to disassemble turbine during warranty period will void warranty. (3 years or 15,000 hours).

Contact your distributor or Ransburg for turbine rebuilding instructions.

## HIGH VOLTAGE CONNECTIONS

Use a small amount of light dielectric grease, part number LSCH0009-00, on the high voltage cable ends to prevent moisture damage and ensure the integrity of the electrostatic system.

## AIR FILTERS / ELEMENT REPLACEMENT

REPLACEMENT ELEMENTS		
Part #	Qty. Elements Per Carton	Used On
RPM-32	4	RPM-417, Pre-Filter
RPM-33	8	RPM-418, Bearing Air Filter

Figure 14: Replacement Elements

## VALVES

No maintenance is normally required on the valve other than flushing solvent through the valve daily. If there is any question about the valve opening when air is present, slide back the rear shroud on the Aerobell 33 and inspect for valve action. Visual inspection for leaks should be made on a weekly basis. Should the valve fail to function properly or leaks appear, it can be easily replaced. Refer to the fluid valves service manual for detailed instructions on preventive maintenance and inspections.

## GENERAL

Verify daily that the operating parameters have not varied from the set up standard. A drastic change in system current, high voltage, turbine air, shaping air pressure, or fluid pilot air pressure can be an early indicator of a component or system problem.

## PREVENTIVE MAINTENANCE

### Daily Maintenance (During Each Preventive Maintenance Break)

Alaminated poster entitled "Rotary Atomizer Checklist", part number AER0075-00, is included with the assembly to be posted near the station as a handy reference.

- Open solvent valves and flush out feed tubes and bell cups for 3-5 seconds (trigger and dump valve closed).

### WARNING

- Make sure high voltage is off before approaching applicator with solvent cloth.
- Do not use reclaim solvent containing d-Limonene. This can cause damage to certain plastic components.
- Do not stop bell rotation by using a rag or gloved hand against the bell cup edge. This can damage the resistance coating at the bell cup edge.

**⚠ CAUTION**

- Maximum flow rate should not exceed 500 cc/minute.

**⚠ CAUTION**

- Daily removal and soaking of the bell cup may not be required if the bell cup is properly flushed as indicated above. However, the frequency of the feed tube and internal motor shaft inspection indicated below under weekly maintenance can be done daily and later adjusted to weekly or as required depending on the results of the inspection.

- Wait for rotation to cease and then clean off bell cup edge and shaping air ring and any other outer surfaces. Use a soft cloth dampened with solvent.
- Visually inspect the bell cup edge for signs of abrasion. If the coating is excessively worn back (1/16 inch (1.6mm) or more) or badly chipped as the result of contact with a part, replace the cup.
- Check bell cup voltage using high voltage probe. Voltage should be approximately 85 kV when 100 kV is set on the power supply.
- Check the amount of paint build up on the outer protective wrap. If excessive, replace wrap as required.

**⚠ WARNING**

- In the event the bell cup comes in contact with a part, that cup should be checked for damage and replaced if necessary before continuing to spray.

**⚠ WARNING**

- Do not place high voltage probe on bell edge unless rotation is fully stopped.

**NOTE**

- Refer to the “Troubleshooting Guide” (Figure 15) for details on determining the causes of low or no high voltage at the bell cup.

**Weekly Maintenance  
(Prior to Start or End of Production Week)**

- Monitor rotational speed of all bells at the speed control (should be within approximately 5% of target speed).

**NOTE**

- The protective disposable wrap is for one time use only. Do not wash and reuse the wrap.

**NOTE**

- Normally the wrap will not need replacement daily and could last about one week. See “Weekly Maintenance” in the “Maintenance” section.

- Monitor high voltage output indicated on the display of the control unit or at the meter of the power supply (should be within approximately 5% of target output).
- Check paint flow on all bells at minimum and maximum specified settings by taking beakered readings.
- Check solvent flow by opening solvent valve and taking a beakered reading (should be within approximately 10% of target flow rate).
- Remove protective wrap from outer housing and discard. Clean any paint on outer surface of front and rear housing with soft cloth dampened with solvent. (See “Warning” under “Daily Maintenance” on avoiding the use of cleaning solvent containing d-Limonene.)

**⚠ CAUTION**

- Maximum flow rate should not exceed 500 cc/minute.

- Check the high voltage connection by removing the cable assembly from the resistor block. Examine the tip of the banana plug for any contaminants or corrosion. Clean or replace the plug as required. Prior to reinstalling the cable assembly, start at the rear of the banana plug and cover about 6 inches (150mm) of high voltage cable with a thin film of dielectric grease. Insert the high voltage cable until the banana plug seats into the connector within the resistor block. The blind depth inside the resistor block

is approximately 7-5/8 inch (193mm). Ensure that the high voltage cable is properly seated, tighten the strain relief, and reinstall the connector cover. In an oscillation or reciprocator type application, always ensure adequate cable slack between the applicator and the power supply termination point.

- Remove the front shroud and check for any signs of solvent or paint leakage. Clean as required.
- Check position of high voltage tube where it enters the motor housing. Make sure the o-ring is not exposed. If so, push the tube in place.
- Remove bell cup and soak in solvent (MEK and Xylene blend) for 1 to 2 hours. Remove from cleaning solution and blow dry before replacing. Make sure the o-ring is not exposed. If so, push the tube in place.



### WARNING

- Do not use reclaim solvent containing d-Limonene to soak bell cups.

### NOTE

- It may be necessary to remove the bell cups for cleaning more frequently than weekly. (See "Caution" under "Daily Maintenance".)

- Inspect the feed tube tip and clean any paint build up that has occurred on the feed tube tip. Using a pen light, determine if there is build up of paint in the motor shaft and/or around the paint feed tube. If so, remove the motor assembly following the disassembly procedures and clean out the inside diameter of the motor shaft using a tube brush and solvent. Clean the outer surfaces of the feed tube.



### WARNING

- Make sure that no solvent or other contamination is allowed to enter the motor assembly (air bearing and outer shaft).

- Release the rear cover fasteners and slide the shroud back to expose the fluid manifold and regulator. Visually inspect for signs of fluid leaks around fluid connections and manifold. Correct problem and clean paint from all components, including internal portion of shroud.

- Reinstall rear shroud, bell cup, and front shroud. Rewrap the outer housing and insulator mounting rod (refer to "Disassembly Procedures" for definite instructions).

### NOTE

- The outer protective wrap may have to be replaced more frequently than weekly. Daily inspection of the amount of paint buildup on the wrap will determine the frequency of replacement.

## HIGH PERFORMANCE THERMOPLASTIC BELL CUP PREVENTIVE MAINTENANCE

It is the user's responsibility to ensure proper maintenance of the atomizer bell at all times. Bell cup failure due to inadequate cleaning or handling will not be covered under warranty. The "Do Not" bullets listed are some examples of improper handling which could adversely affect performance or personnel safety and should not be attempted for any reason.

## BELL CUP CLEANING

Always verify that high voltage is turned OFF and that the atomizer bell is spinning before performing any type of color change or bell flush cleaning cycle.

To reduce the risk of fire or explosion, the solvents used for exterior cleaning must have flash points above 100° F (37.8° C). Since electrostatic equipment is involved, these solvents should also be non-polar.

Solvents used for equipment flushing should have flash points equal to or higher than those of the coating material being sprayed.

1. The atomizer bell includes a self-cleaning feature, and will normally be fully cleaned during a bell flush cycle. Flushing should be done before any down time or break in production. A bell flush cycle may also be required while spraying batch parts of the same color. Verify that high voltage is **OFF** and that the atomizer bell is spinning before flushing through the bell.

2. If there is any remaining paint build up on any areas of the bell after flushing, the bell should be removed for hand cleaning (reference "Bell Cup Handling" listed on the back side of this data sheet). The bell's leading edge, paint feed holes or slots, and serration cuts are some examples of areas for special attention.
3. Visually inspect the bell cup edge for signs of abrasion. If the coating is excessively worn back (1/16 inch (1.6mm) or more) or badly chipped as the result of a collision with a part, replace the cup immediately.
4. Soaking the bell in solvent will not aid in loosening or removing paint build up! The bell should be dipped in an appropriate solvent or the solution may be allowed to flow over and into the bell while cleaning.
5. Use a soft bristle brush dipped in solvent to remove paint build up from the serration cuts, paint feed holes or slots, and external and internal surfaces of the bell. With a light source shining into the rear of the bell, any contamination in the paint feed holes will be easily seen when viewed from the front face.
6. A soft, lint free rag dampened with solvent may be used to remove any paint residue from the external and internal surfaces of the bell.
7. After removing all paint build up or residue, rinse the bell in clean solvent and blow dry.
8. Before reinstalling the bell onto the shaft, check the mating surfaces of the thread and taper for any paint build up or residue. Also check the fluid tube outside diameter and the shaft bore for any further paint build up. These surfaces should be cleaned before installing the bell.
9. A ring of semi-conductive coating should also be visible just inside the bell taper, which will contact the shaft when properly seated. If a contact area is not found, replace the cup.

Install and tighten the bell according to the atomizer service manual.

## BELL CUP TESTING (NON-ROTATING)

Check bell cup voltage using Ransburg test meter kit, part number 76652-01 or 76652-04. Verify that the output voltages have not varied much from the set up standard. A drastic change in voltage can be an early indicator of a component or system problem. The data shown below was collected under ideal lab conditions using a clean atomizer and an unloaded fluid delivery system.

- The following data is for use with the RMA-101 or Aerobell 33R atomizers. The output voltage measured at the bell will normally range between 91% and 97% of the kV set point displayed at the control unit.
- The following data is for use with the Aerobell 33 atomizer. The output voltage measured at the bell will normally range between 85% and 91% of the kV set point displayed at the control unit.

### Bell Cup Handling

Always verify that high voltage is turned **OFF** and the atomizer bell has stopped spinning before performing any type of handling maintenance.

## OPERATOR / MAINTENANCE

### \*\*\*WARNINGS\*\*\*



**Do not** attempt to hold a rag or a gloved hand against the bell edge to stop or slow down a rotating bell.



**Do not** attempt to clean the bell edge while the bell is rotating.



**Do not** attempt to use sharp or abrasive materials to clean the bell, which will scratch or damage the plastic bell.



**Do not** use sharp or abrasive materials to clean the bell, which will scratch the semi-conductive coating on the surface of the bell.



**Do not** attempt to place a high voltage probe on the bell edge unless rotation is full stopped.



**Do not** use ultrasonic devices to clean the atomizer bell cup.



**Do not** use ammonia solutions or reclaim solvent containing d-Limonene to clean the bell cups.



**Do not** use the bell cup to spray coatings containing N-methyl pyrrolidone.



**Do not** use N-methyl pyrrolidone to clean the bell cup.



**Do not** reuse an atomizer bell that shows signs of damage such as nicks, heavy scratches, dents, or excessive wear (defined under "Bell Cup Cleaning", bullet number 3).

## LOW VOLTAGE TEST

When replacing the resistive components, troubleshooting, reassembling or as periodic inspection procedure, a "low voltage" test can be performed on the rotator assembly to ensure that there are good electrical contacts and that the resistors are not defective. A high voltage resistor tester (Megger) must be used which has an output voltage of 500 to 1000 VDC.

1. With the high voltage turned OFF, disconnect the high voltage cable from the rear of the rotator assembly.
2. Insert a test cable or the test meter probe into the rear of the rotator and connect to the voltage output of the test meter.
3. Remove the front shroud and bell cup and clip the test meter ground to the rotator shaft.
4. Set the test meter voltage output to a minimum of 500 VDC and maximum of 1000 VDC.
5. The meter should indicate between approximately 725 megohm and 770 megohm. If the test instrument is reading higher than 770 megohm, then the electrical contacts between the resistor tube, resistor block and motor assembly need to be checked.
6. Remove the motor assembly and resistor tube and verify that the resistor tube springs are at least 3/8" (10mm) and are not distorted. Also make sure that there is no visible contamination in the motor cavity where the resistor tube inserts.

Refer also to the "Troubleshooting Guide" (Figure 15).

## DISASSEMBLY PROCEDURES

Make sure the following conditions exist prior to disassembly:

- Pay particular attention to the procedures and **WARNING** information, outlined under "Cleaning Procedures", prior to performing any maintenance.
- The air to all supply and pilot lines is off.
- The high voltage power supply has been shut off.

- The atomizer's valves, feed tube, bell cup, and fluid supply lines have been cleaned with solvent and purged dry with air.

### NOTE

- For reassembly instructions, use the reverse of the following disassembly procedures.

- The bell cup has stopped rotating.
- All external surfaces must be clean and free of paint or paint residue.

### Front Shroud Removal

Remove the front shroud (Figure 16a, item 2) from the atomizer, using the RPM-419, or other properly fitting spanner wrench, and turning CCW (viewed as facing the front end).

Note that when the front shroud is removed, the shaping air cap (Figure 16a, item 13) is removed with it. The Aerobell 33 turbine (Figure 16a, item 10) and the bell assembly (Figure 16a, item 16) will now be exposed.

Using the same wrench, it is also possible to separate the shaping air cap from the front shroud. This is much easier to do if the front shroud is mounted on the turbine assembly, since it is difficult to grasp the shroud and the wrench simultaneously if the parts are removed from the mechanical support of the assembly. Hold the front shroud stationary while turning the shaping air ring CCW. Note that it is only necessary to separate these parts if replacing one of them, or for thorough cleaning.

When installing the front shroud onto the turbine assembly, be sure that it is fully tightened. The shroud will appear tight after a few turns, but will still be loose. The shroud can then be tightened down fully until it bottoms against the air manifold assembly.

## Atomizer Bell Cup Removal

To remove the atomizer bell cup (Figure 16a, item 16), place the wrench (P/N RPM-419) over the flats on the motor shaft to lock in place. Unscrew the bell by turning CCW with the other hand (facing the front of the atomizer). If the bell cannot be removed by hand, use a second wrench (P/N RPM-419) placed over the wrench flats of the bell cup.

Refer to "Preventive Maintenance" in the "Maintenance" section for important information about bell and shaft cleanliness. Do not install a paint contaminated or damaged bell on the turbine shaft. When installing the bell on the shaft, the bell should be firmly secured by hand or use wrench, RPM-419, and torque to 50 lb•in -0/+40 lb•in (5.6 N•m -0/+4.5 N•m).

## Turbine Removal

The turbine assembly (Figure 16a, item 10) is removed from the Aerobell 33 atomizer after removing the front shroud assembly. Four mounting bolts (Figure 16a, item 8) will then be exposed, which hold the turbine assembly to the air manifold assembly. These are the larger socket head screws, located toward the outer edge of the motor housing.

Holding the turbine assembly carefully so that it does not drop and using a 5/32 inch wrench, remove the four mounting screws which hold the turbine to the air manifold. Pull the turbine assembly straight forward until it is beyond the end of the fluid tube (Figure 16a, item 3) and the high voltage tube (Figure 16a, item 6) is out of the resistor block (Figure 16a, item 22).

The turbine assembly can now be replaced or serviced as necessary.

**Reassemble Note:** Prior to replacing the turbine assembly, make sure the bearing air o-ring (Figure 16a, item 11) is in place on the air manifold assembly (Figure 16a, item 1). To replace the turbine assembly, center the turbine shaft with the feed tube, align the high voltage tube with the resistor block, the shaping air tube with the air manifold, and push the turbine assembly slowly in. Holding the turbine securely in place, screw the four mounting bolts (Figure 16a, item 8) through the rear of the turbine assembly into the air manifold assembly. Tighten the four mounting bolts alternately to a final torque of 15 lb•in (1.7 N•m).

**Reassemble Note:** When the resistor module is installed onto the high voltage tube, an air pocket can form inside the resistor module passage. This air pocket can force the resistor module out of its seat. Take care that the resistor module is securely seated into the rear bulkhead slot.

## ⚠ CAUTION

- ▶ Make sure the turbine assembly is properly seated by examining the fit between the rear of the turbine assembly and the front of the air manifold assembly. Any irregularity in this seam between the two assemblies would indicate improper mounting.

Looking into the front of the motor shaft, observe the concentricity of the paint feed tube to the inside of the motor shaft. If the paint feed tube is off center by more than .020-.028 inches (.51 -.71mm) radially the motor assembly may not be seated properly.

Do not use the four mounting bolts to pull the turbine assembly into air manifold. This can cause the thread to be damaged. Torque the four mounting bolts to 15 lb•in (1.7 N•m).

## ⚠ WARNING

- ▶ Using the RPM-419, wrench, a minimum of 50 lb•in (5.6 N•m) of torque must be applied when tightening the bell cup onto the motor shaft to deter the bell cup from spinning off the shaft if the motor seizes.
- ▶ Operating the turbine motor when it is not properly fitted to the air manifold can cause severe damage to the motor, bell assembly and/or operating personnel.

## Rear Shroud Removal

The rear shroud (Figure 16a, item 33) can be removed for cleaning or inspection of the components on the inside of the assembly

Loosen the two captive screws (Figure 16a, item 28) by turning them inward (clockwise). Slide the shroud backward over the hoses and high voltage cable. Note that it is not necessary to remove the shroud completely from the hoses. Slide it backward (over the hoses) for easy accessibility to the components such as valves.

If space parameters require that the spacing between the rear bulkhead and the mounting bar be less than the recommended 10 to 12 inch (250 to 300mm), the Aerobell 33 can be swiveled on the insulator support so the rear shroud can be slid back fully.



If the outside or inside surfaces of the shroud are dirty, wipe clean with a solvent damp rag.

### Resistor Module Removal

To remove the high voltage cable from the resistor module, first remove the retaining screw (Figure 16a, item 21) and slide the connector cover (Figure 16a, item 20) back over the cable. Then loosen the strain relief nut and pull the cable straight out of the module.

To remove the resistor module (Figure 16a, item 22), follow the procedures for removal of the rear shroud. Then slightly lift the rear of the module to clear the step in the rear bulkhead (Figure 17, item 12) and slide it backward until completely separated from the forward high voltage tube (Figure 16a, item 6).

#### CAUTION

- When reinstalling the resistor module, care should be taken to avoid damage to the high voltage tube. Also, make sure the rear of the resistor module is properly seated in the pocket before sliding the rear shroud forward. If the resistor housing is not properly seated and the rear shroud is forced into place, damage can occur to the rear shroud.

### Fluid Regulator Removal

To remove the fluid regulator (Figure 16a, item 18) follow the procedures for removal of the rear shroud. Then disconnect the air pilot lines at the regulator, and the output fluid line at its connection into the fluid manifold assembly (Figure 16a, item 7). Disconnect the fluid supply line at the regulator inlet port, loosen the retaining screws, and pull the regulator straight out of the bulkhead.

### Fluid Manifold Valve Removal

To remove the fluid manifold assembly (Figure 16a, item 7) follow the procedures for removal of the rear shroud. Then disconnect the air pilot lines at the tube connection of each individual valve.

Disconnect all fluid connections including the dump line, paint, and solvent supply lines from the fluid manifold. Then using a medium flat head screwdriver, remove the mounting screws (Figure 16a, item 9) and pull the manifold

#### NOTE

- The four screws holding in the regulator are held captive. They do not back out completely of the regulator.

#### WARNING

- Fluid pressure must be shut off and pressure relieved by actuating the valves prior to removal.

straight back to separate it from the fluid tube. To remove each individual fluid valve from the manifold use a 7/8 inch open-end wrench, and turn the valve CCW to disengage the threads. Then pull the valve straight out of the manifold.

### Speed Transducer Removal

To remove the speed transducer, follow the procedures for removal of the rear shroud. Then loosen the compression nut on the transducer body, and pull the fiber-optic cable out. Using an 11/16 inch open-end wrench, turn the speed transducer CCW to disengage the threads completely, and then pull the unit straight out of the air manifold.

### Fluid Tube Removal

To remove the fluid tube assembly (Figure 16a, item 3), follow the procedures for removing the rear shroud and fluid manifold assembly. Once the fluid manifold is removed, the fluid tube will be exposed at the rear of the air manifold. Using a standard 3/4 inch socket, engage the hexagon flats on the feed tube, and turn CCW to loosen. After disengaging the threads completely, pull the feed tube straight out of the air manifold.

#### CAUTION

- Care should be taken to not overtighten the fluid tube and strip the threads.

When installing a new or old feed tube, once it is securely tightened, check the position of the feed tube in the shaft at the front of the assembly. If the feed tube is off center by more than .020-.028" (.5-.7mm) radially, replace it with another feed tube. If the feed tube protrudes out of the shaft a distance other than .207"-.015 / +.030 (5.2mm - .4/+ .8), replace the tube with another feed tube.



## TROUBLESHOOTING GUIDE (Cont.)

General Problem	Possible Cause	Solution
<b>Bad Spray Pattern</b>	Bell cup damaged	Replace bell cup.
	Low voltage	See "low or no voltage" below.
	Bad fluid regulator	Repair or replace fluid regulator.
	Paint lodged in shaping air ring.	Disassemble and clean.
<b>Low or No High Voltage</b>	High current draw	Paint resistivity to be .1 MΩ to ∞.
	Solvent valve is actuated	Remove solvent valve air pilot signal (high voltage must be interlocked with the solvent valve air pilot signal to prevent solvent flow while high voltage is energized).
	Loss of high voltage connection at the power supply	Ensure proper high voltage connection at the power supply. Refer to "Low Voltage Test" in the "Weekly Maintenance" section of this manual.
	Loss of high voltage connection at the resistor module	Verify high voltage connection into the resistor module. Refer to "Low Voltage Test" in the "Weekly Maintenance" section of this manual.
	Loss of high voltage connection at the turbine assembly	Verify high voltage tube connection into the turbine housing and resistor module. Refer to "Low Voltage Test" in the "Weekly Maintenance" section of this manual.
	Power supply failure	Refer to the power supply manual for detailed troubleshooting guide.
	Improper limiting current and voltage settings	To readjust settings, refer to the power supply manual.
	Atomizer grounding out (usually indicated by high current draw)	<ul style="list-style-type: none"> <li>a. Clean atomizer externally with non-polar solvent.</li> <li>b. Check the atomizer for internal fluid leaks.</li> <li>c. Check for internal arcing (usually indicated by internal sparking sounds).</li> </ul>
	Damaged high voltage cable between atomizer and power supply	Repair or replace high voltage cable.
	Improper color change (i.e., paint or solvent in dump line)	Optimize color change.

Figure 15: Troubleshooting Guide

(Continued On Next Page)



## TROUBLESHOOTING GUIDE (Cont.)

General Problem	Possible Cause	Solution
<b>Low Transfer Efficiency (or light coverage)</b>	Low or no high voltage	Verify high voltage at bell cup edge. Normally, a high voltage setting of 100kV is appropriate for most applications.
	Poor grounding of parts being coated	Verify that parts being coated are properly grounded (the electrical resistance between the part and ground must not exceed 1 megohm).
	Excessive turbine speed	For optimum transfer efficiency and spray pattern control, the bell rotational speed should be set at the minimum required to achieve proper atomization of the coating material.
	Excessive shaping air	Shaping air should be set at the minimum volume required to gently direct the spray pattern toward the part being coated. Excessive shaping air will cause some atomized particles to "blow-by" the part or bounce back onto the atomizer.
	Excessive target distance	The recommended target distance is between 8 and 12 inches (200-300mm) (see "Target Distance" in the "Operation" section of this manual).
<b>No Turbine Air</b>	Turbine drive air not present	Verify supply air pressure.
	Bearing air return signal not present	a. Verify bearing air return signal. b. Increase bearing air supply pressure to 90 psig $\pm$ 10 (620 kPa $\pm$ 69).
	Brake air is activated	Remove brake air signal (turbine air and brake air must be interlocked to prevent both from being used simultaneously).
<b>Speed Feedback Fault</b>	Damaged fiber-optic cable between atomizer and control panel	Repair or replace fiber-optic cable.
	Connection at the fiber-optic transmitter is loose	Re-install fiber-optic cable and tighten the compression nut.
	Fiber-optic transmitter failure	Replace fiber-optic transmitter.
<b>No Fluid Flow</b>	Turbine is not rotating	Verify rotation of turbine (the paint valve air pilot must be interlocked with the turbine speed feedback signal to ensure that paint does not flow into the air bearing).
	Fluid regulator does not actuate	a. Verify fluid supply. b. Verify that air pilot signal is present.

Figure 15: Troubleshooting Guide (Continued)

(Continued On Next Page)



## TROUBLESHOOTING GUIDE (Cont.)

General Problem	Possible Cause	Solution
<b>No Fluid Flow (Continued)</b>	Fluid valve does not actuate	a. Verify that air pilot signal is present. b. Fluid valve air pilot pressure is too low. Increase air pressure to 70 psig (480 kPa) minimum. c. Replace fluid valve.
	Clogged fluid tube	Remove and inspect fluid tube.
<b>Continuous Fluid Flow</b>	Fluid valve open	a. Remove air pilot signal. b. If still open, replace fluid valve.
	Fluid valve seat damaged or worn	Replace fluid valve seat.
<b>Uncontrollable Fluid Flow</b>	Insufficient back pressure to fluid regulator	Replace fluid tube with the next smaller inner diameter size.
	Fluid regulator does not control flow	Disassemble fluid regulator and inspect for failed components.
<b>Fluid Leakage Around Fluid Valve</b>	Damaged O-ring(s) on outer diameter of valve body	Replace O-ring(s).
	Damaged or worn needle seals inside valve assembly	Replace valve assembly.
<b>Fluid Leakage Around the Fluid Regulator Cap</b>	Regulator cap is loose	Disassemble, clean, and reassemble. Tighten regulator cap hardware.
	Ruptured diaphragm	Replace diaphragm.
	Pinched or cut O-ring between lower support washer and diaphragm	Replace O-ring.

Figure 15: Troubleshooting Guide (Continued)

(Continued On Next Page)

# PARTS IDENTIFICATION

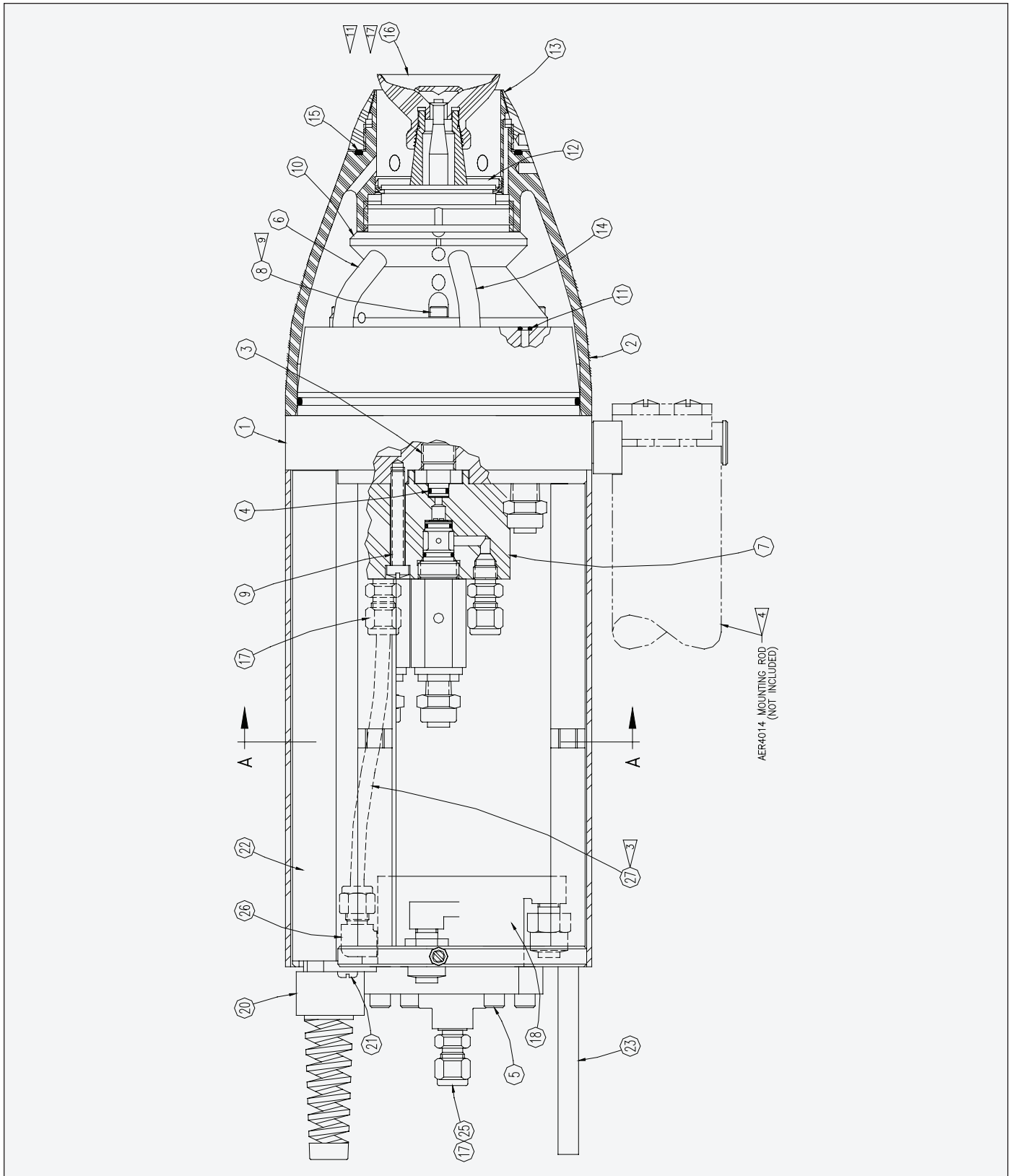

Figure 16a: Aerobell 33 Cross Section View

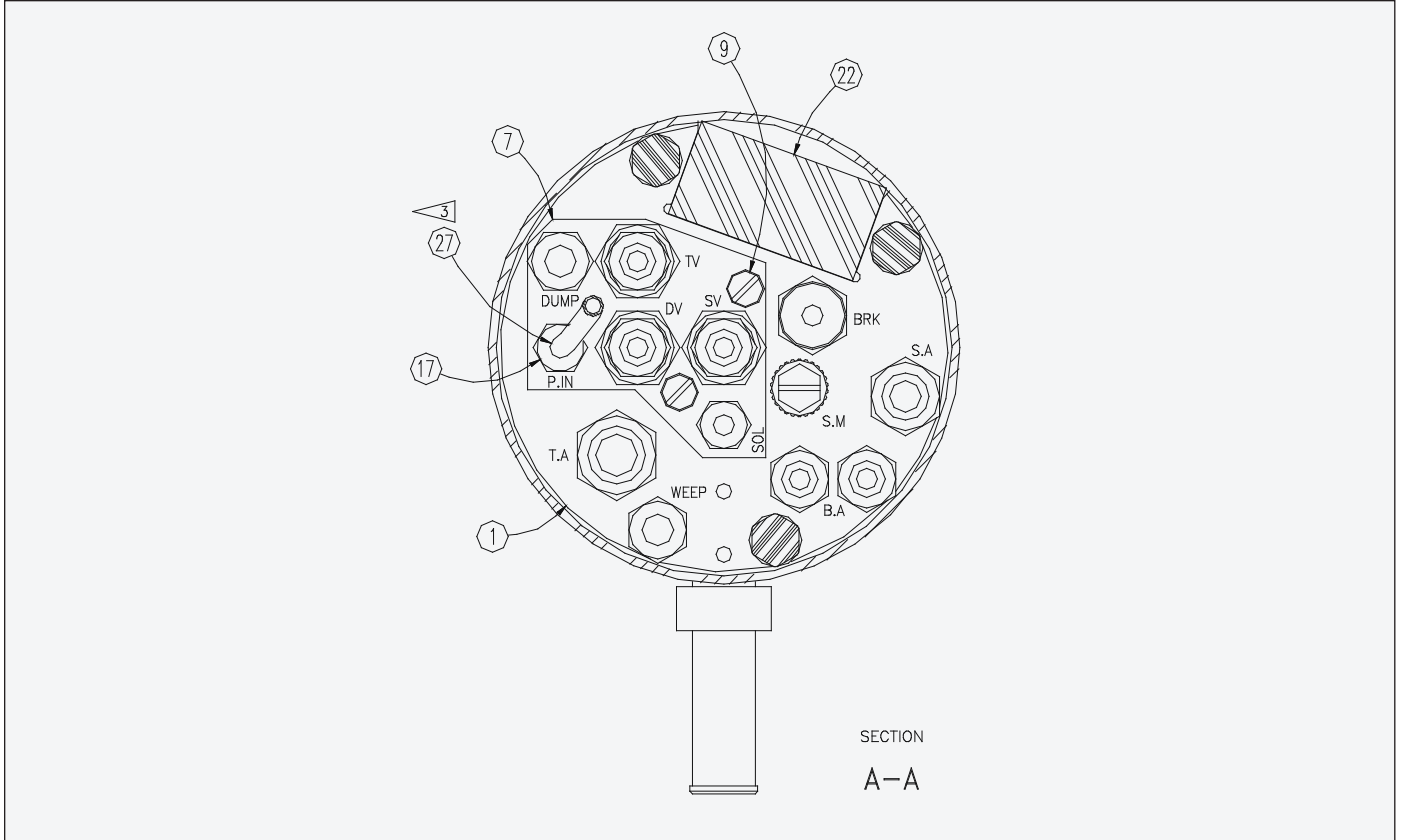

Figure 16b: Aerobell 33 Cross Section View

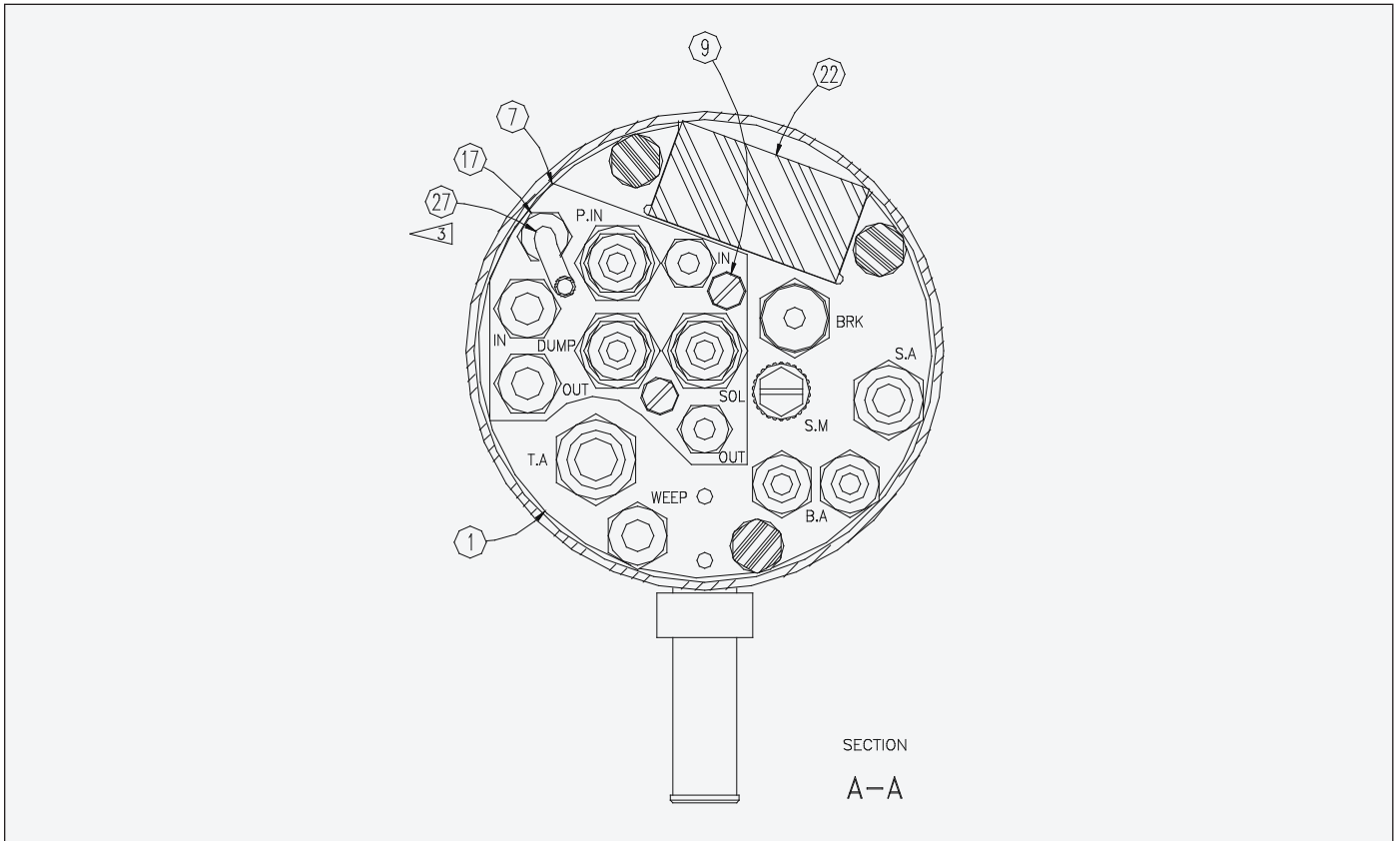

Figure 16c: Aerobell 33 Cross Section View

## AEROBELL 33 MODEL IDENTIFICATION

When ordering, use part number AER5001-ABCDE as indicated by Tables A through E.

- Table A: Designates the bell type
- Table B: Designates the fluid tube
- Table C: Designates the fluid manifold assembly
- Table D: Designates the regulator assembly
- Table E: Designates the resistor block

(Five characters must follow the the basic part number as shown in the example below.)

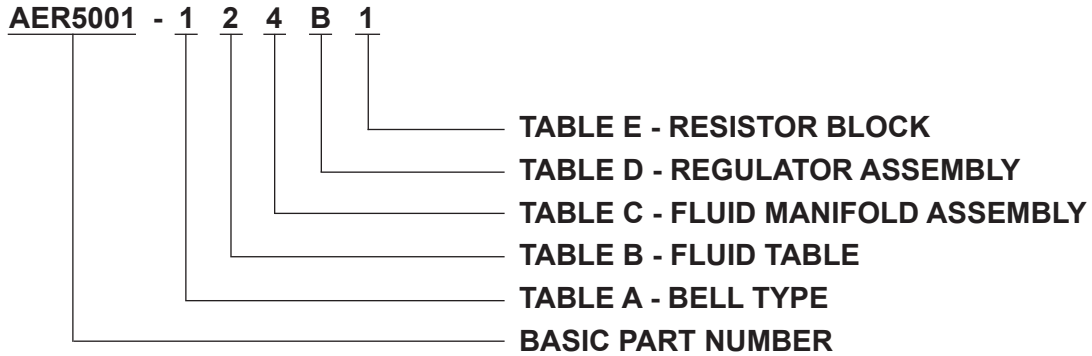

### TABLE "A" - BELL TYPE

Dash No.	Description	N	J	M
5	Aerobell 33 Assembly w/57mm Bell Cup w/Secondary Charging Ring	AER4016-03	AER0020	RPM-5
6	Aerobell 33 w/30mm Bell Cup w/Holes & Secondary Charging Ring	AER4015-05	AER0038	RPM-80
7	Aerobell 33 w/30mm Bell Cup w/Slots & Secondary Charging Ring	AER4015-06	AER0038	RPM-80

### TABLE "B" - FLUID TUBE

Dash No.	Description	K
1	S.S. Fluid Tube, .041 I.D.	76416-04
2	S.S. Fluid Tube, .093 I.D.	76416-09
3	S.S. Fluid Tube, .125 I.D.	76416-12
4	S.S. Fluid Tube, .061 I.D.	76416-06

**TABLE "C" - FLUID MANIFOLD ASSEMBLY**

Dash No.	Description	L
1	Fluid Manifold Assembly, Trigger	AER4000
2	Fluid Manifold Assembly, Trigger/Dump	AER4001
3	Fluid Manifold Assembly, Trigger/Solvent	AER4002
4	Fluid Manifold Assembly, Trigger/Dump/Solvent	AER4003
5	Waterbase Fluid Manifold Assembly, Trigger	AER4020
6	Waterbase Fluid Manifold Assembly, Isolated Dump	AER4021
7	Waterbase Fluid Manifold Assembly, Isolated Solvent	AER4022
8	Waterbase Fluid Manifold Assembly, Isolated Dump/Solvent	AER4023

**TABLE "D" - REGULATOR ASSEMBLY**

Dash No.	Description	R	S	T	Y	Z	RR
2	1/4 or 3/8 O.D. Supply w/o Fluid Regulator	1	0	N/A	1	0	1
A	1/4 O.D. Supply w/Fluid Regulator, 1:1 Low Flow	2	1	LREG5001-01	0	1	0
B	1/4 O.D. Supply w/Fluid Regulator, 1:2 Low Flow	2	1	LREG5001-02	0	1	0
C	1/4 O.D. Supply w/Fluid Regulator, 1:3 Low Flow	2	1	LREG5001-03	0	1	0
D	1/4 O.D. Supply w/Fluid Regulator, 1:4 Low Flow	2	1	LREG5001-04	0	1	0
E	1/4 O.D. Supply w/Fluid Regulator, 1:6 Low Flow	2	1	LREG5001-06	0	1	0
F	1/4 O.D. Supply w/Fluid Regulator, 1:8 Low Flow	2	1	LREG5001-08	0	1	0
G	1/4 O.D. Supply w/Fluid Regulator, 1:10 Low Flow	2	1	LREG5001-10	0	1	0
H	3/8 O.D. Supply w/Fluid Regulator, 1:1 Low Flow	1	1	LREG5001-11	0	1	1
J	3/8 O.D. Supply w/Fluid Regulator, 1:2 Low Flow	1	1	LREG5001-12	0	1	1
K	3/8 O.D. Supply w/Fluid Regulator, 1:3 Low Flow	1	1	LREG5001-13	0	1	1
L	3/8 O.D. Supply w/Fluid Regulator, 1:4 Low Flow	1	1	LREG5001-14	0	1	1
M	3/8 O.D. Supply w/Fluid Regulator, 1:6 Low Flow	1	1	LREG5001-16	0	1	1
N	3/8 O.D. Supply w/Fluid Regulator, 1:8 Low Flow	1	1	LREG5001-18	0	1	1
P	3/8 O.D. Supply w/Fluid Regulator, 1:10 Low Flow	1	1	LREG5001-20	0	1	1

**TABLE "E" - RESISTOR BLOCK**

Dash No.	Description	V	W	X
1	Resistor Block, 650 Megohm	1	1	AER4012



### AEROBELL 33 - PARTS LIST (Figure 16)

Item #	Part #	Description	Qty	Notes**
1	AER4004-01	Manifold Assembly, Air	1	
2	See "J" (Table "A")	Shaping Air Cap w/Shroud	1	
3	See "K" (Table "B")	Fluid Tube	1	
4	79001-05	O-Ring, Solvent Proof	1	
5	LSFA0014-00	Screw, Retaining	4	
6	AER4013-00	Tube Assembly, High Voltage	1	
6A	79001-05	O-Ring, Solvent Proof	(Ref)	
7	See "L" (Table "C")	Manifold Assembly, Fluid	1	
8	LSFA0006-16F	Screw, #10-32 x 1/2 Long SST. Socket Head Cap	4	
9	LSFA0004-56C	Screw, 1/4-20 x 1-3/4 Long Nyl. Fill. Head	2	
10	AER4006-00	Turbine Assembly, Air Bearing	1	 
	7554-103	Turbine Assembly O-Ring, Solvent Resistant	1	
	7554-104	Turbine Assembly O-Ring, Solvent Resistant	1	
11	7554-03	O-Ring, Solvent Resistant	1	
12	RPM-2	Retainer, Shaping Air Cap	1	
13	See "M" (Table "A")	Ring, Shaping Air	1	
14	SSP-5020	Tubing, 3/8 O.D.	2.75"	
15	LSOR0005-01	O-Ring, Solvent Proof	1	
16	See "N" (Table "A")	Bell Cup Assembly	1	
17	LSFI0022-04	Fitting, 1/4 O.D. Tube x 1/4 AN Union	<b>R*</b>	
18	See "T" (Table "D")	Regulator Assembly, Fluid	<b>S*</b>	
20	AER0043-00	Cover, Connector, Machined	<b>V*</b>	
21	LSFA0007-12C	Screw, #10-24 x 3/8 Long Nyl. Pan Head	<b>W*</b>	
22	See "X" (Table "E")	Module, Voltage	1	
22A	76419-00	Strain Relief, High Voltage Cable	(Ref)	
23	SSP-5020	Tubing, 3/8 O.D.	12"	
24	AER0063-00	Cover, Rear Plate (Not Shown)	<b>Y*</b>	
25	LSFI0022-07	Fitting, 3/8 O.D. Tube x 3/8 AN Union	<b>RR*</b>	
26	LSFI0041-01	Elbow, 1/4 O.D. Tube x 1/8 NPT, Special	<b>Z*</b>	
27	55994-28	Tubing, 1/4 O.D.	7"	
28	77141-00	Kit, Literature, Aerobell 33	1	

\* See corresponding table and column on pages 38 & 39

\*\* See "Parts List Bullet Definition Table" on page 40

 .300" dia. (Ref) of feed tube 76416-XX to be concentric to .500" I.D. (Ref) of shaft AER0032 (Ref) to within .020"-.028" radially; Use AER0076-01 (Ref) center checking gauge to check feed tube location.

 Rebuild air motor/bearing using AER4019 kit (not included with this assembly).

 Warning: Torque to 50 lb•in +40/-0 lb•in.

 Tighten screws alternately to a final torque of 15 lb•in.

 AER4014 support assembly is shown for reference only, is not included with this assembly and must be ordered separately.

 Must be connected between "P.OUT" on fluid regulator and "P.IN" on fluid manifold assembly.

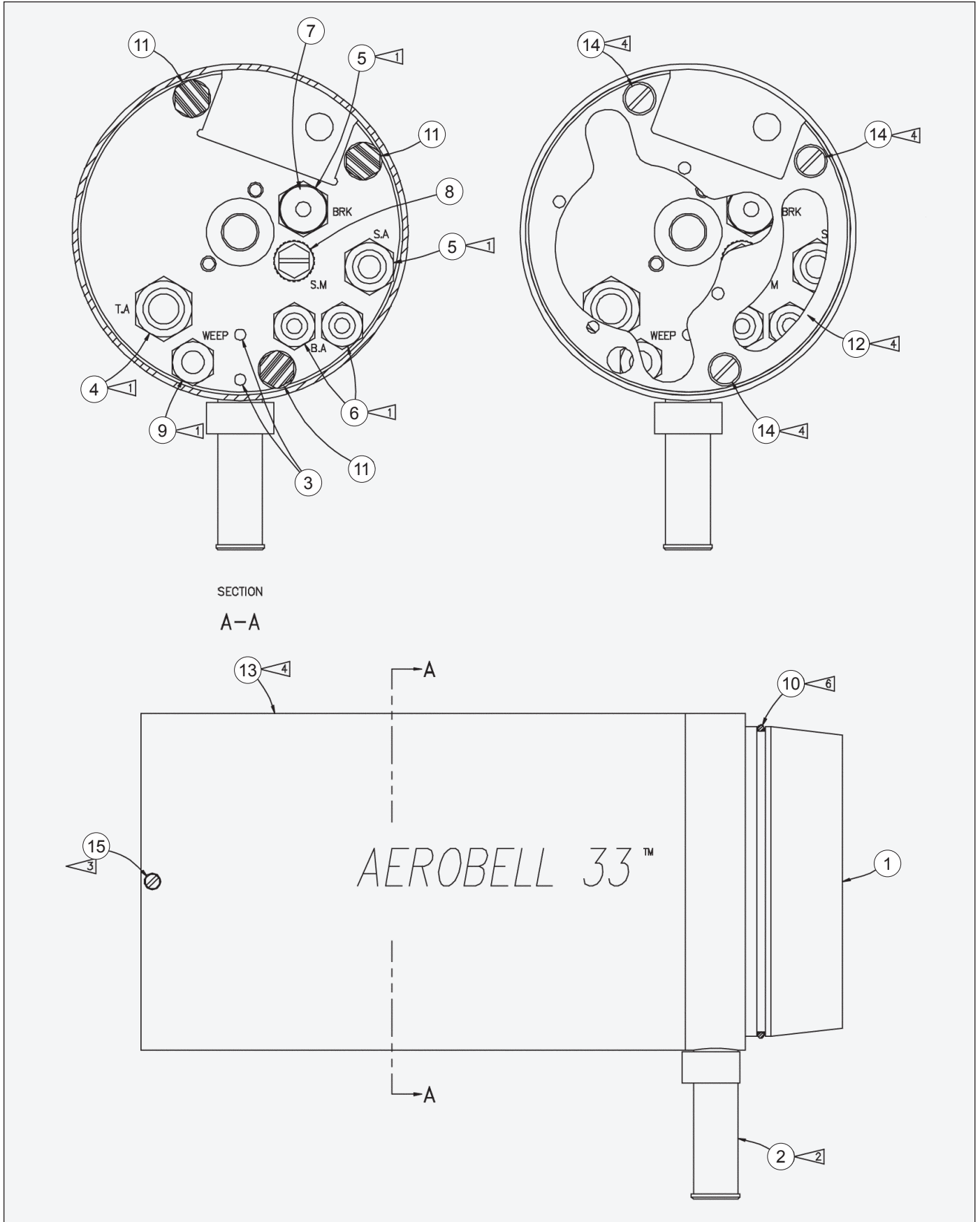









Figure 17: Manifold Assembly

**AER4004-01 MANIFOLD ASSEMBLY - PARTS LIST (Figure 17)**

Item #	Part #	Description	Qty	Notes**
1	AER4005-00	Manifold, Air, Engraved	1	
2	AER0026-00	Stud, Mounting	1	
3	AER0022-00	Pin, Fiberglass	2	
4	LSFI0013-01	Fitting, 1/2 O.D. Tube x 3/8 NPT	1	
5	LSFI0013-02	Fitting, 3/8 O.D. Tube x 1/4 NPT	2	
6	LSFI0013-04	Fitting, 1/4 O.D. Tube x 1/4 NPT	2	
7	LSFI0023-02	Plug, 3/8 O.D. Tube Fitting	1	
8	LSFI0024-03	Plug, 1/2-20	1	
9	LSFI0025-22	Fitting, 3/8 O.D. Tube x 3/8 NPT	1	
10	LSOR0005-02	O-Ring, Solvent Proof	1	
11	AER0021-00	Rod, Rear Plate Support	3	
12	AER0062-01	Plate, Rear	1	
13	AER0027-00	Shroud, Rear	1	
14	LSFA0001-16C	Screw, 1/4-20 x 1/2 Long Nyl. Pan Head	3	
15	AER0023-00	Fastener, Rear Cover	2	

\* See "Parts List Bullet Definition Table" below.

-  Do not use any lubricant; O-ring must remain dry.
-  Place rear shroud over assembly before securing rear plate.
-  Install rear cover fasteners below the surface of rear plate before installing the rear shroud. To lock the shroud into position, align the mounting holes (with the fasteners) and rotate each fastener counter-clockwise until it fits snugly against the shroud.
-  Orient mounting stud with flat towards front, as shown.
-  Apply 59915-01 tape to all male pipe threads.

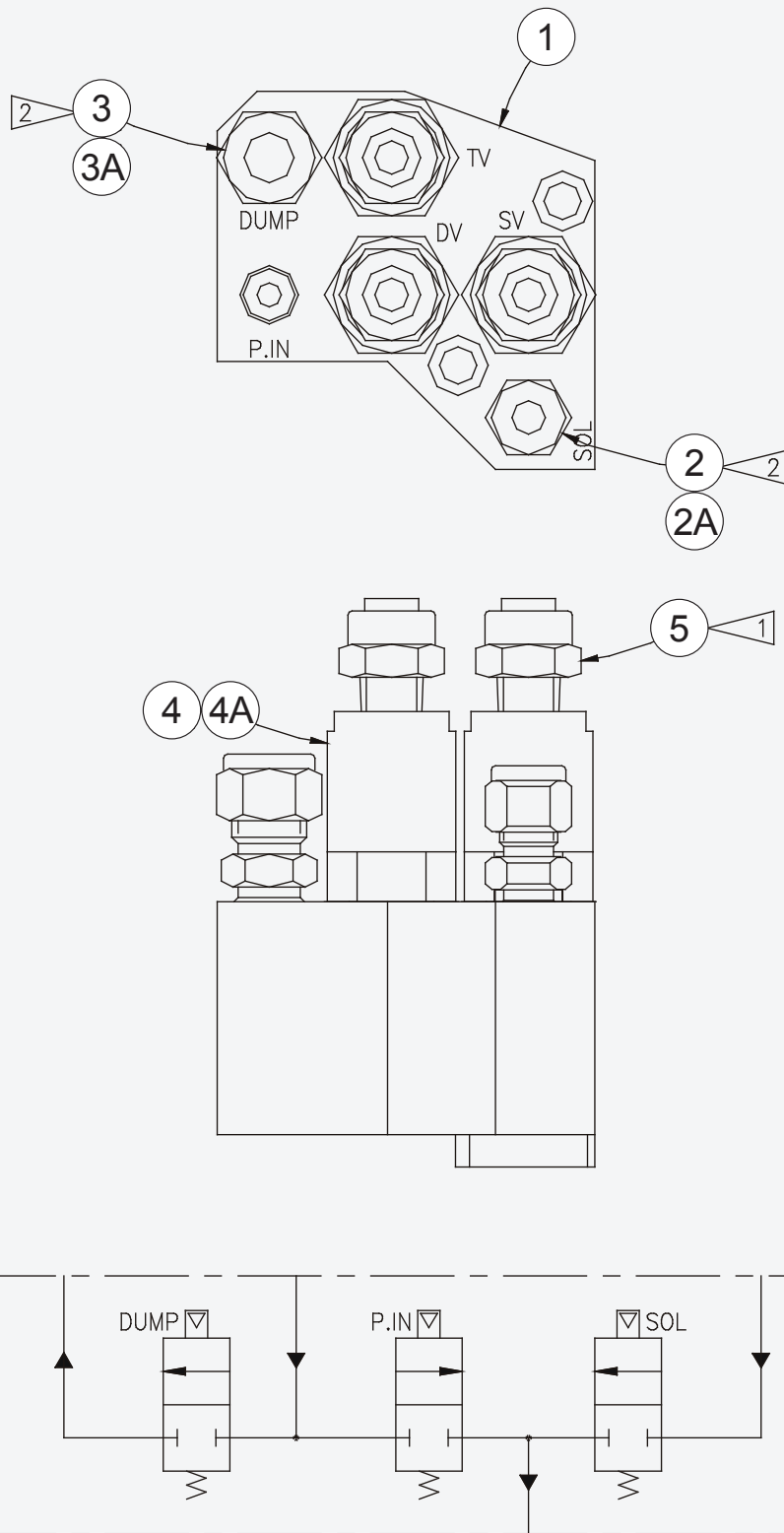





Figure 18: Fluid Manifold Assembly

**FLUID MANIFOLD ASSEMBLY - PARTS LIST (Figure 18)**

Item #	Part #	Description	Qty				Notes*
			AER4000-00	AER4001-00	AER4002-00	AER4003-00	
1	AER0017-00	Manifold, Fluid, Engraved	1	1	1	1	
2	LSFI0022-04	Fitting, 1/4 O.D. Tube x 1/4 AN Union	1	1	2	2	
2A	LSMM0035-03	Plug, Protective, 1/4 AN	1	1	---	---	
3	LSFI0022-07	Fitting, 3/8 O.D. Tube x 3/8 AN Union	---	1	---	1	
3A	LSMM0035-05	Plug, Protective, 3/8 AN	1	---	1	---	
4	76917-00	Valve Assembly, Cartridge, HV	1	2	2	3	
4A	AER4018-00	Plug Assembly, Valve Port	2	1	1	---	
5	LSFI0013-03	Fitting, 1/4 O.D. Tube x 1/8 NPT	1	2	2	3	

\* See "Parts List Bullet Definition Table" below.

 Install fitting hand-tight, then 1/4 turn with wrench.

 Apply 59915-01 tape to all male pipe threads.

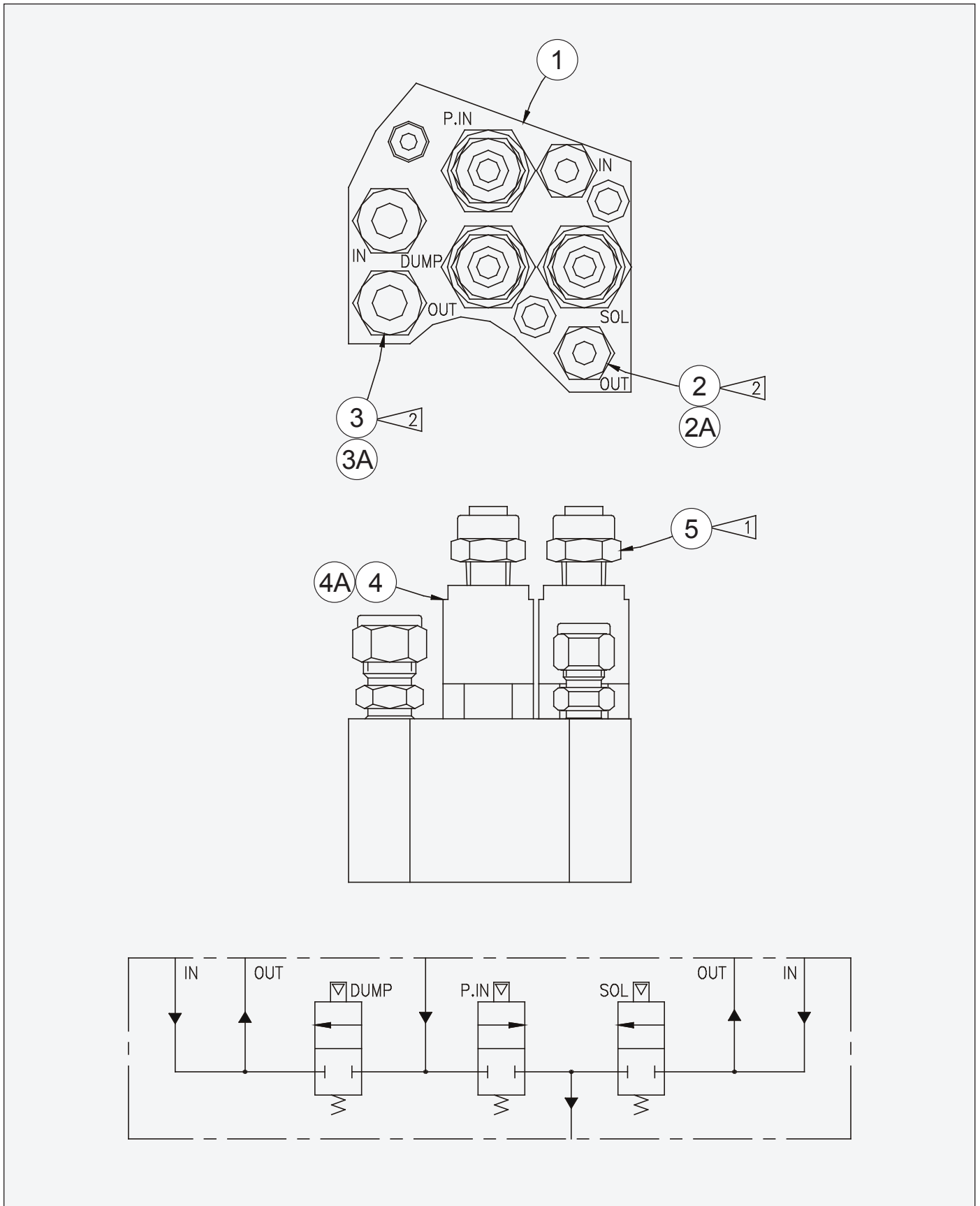

Figure 19: Waterborne Fluid Manifold Assembly

**WATERBORNE FLUID MANIFOLD ASSEMBLY - PARTS LIST (Figure 19)**

Item #	Part #	Description	Qty				Notes*
			AER4020-00	AER4021-00	AER4022-00	AER4023-00	
1	AER0068-00	Manifold, Fluid, Engraved	1	1	1	1	
2	LSFI0022-04	Fitting, 1/4 O.D. Tube x 1/4 AN Union	---	---	2	2	2
2A	LSMM0035-03	Plug, Protective, 1/4 AN	2	2	---	---	
3	LSFI0022-07	Fitting, 3/8 O.D. Tube x 3/8 AN Union	---	2	---	2	2
3A	LSMM0035-05	Plug, Protective, 3/8 AN	2	---	2	---	
4	76917-00	Valve Assembly, Cartridge, HV	1	2	2	3	
4A	AER4018-00	Plug Assembly, Valve Port	2	1	1	---	
5	LSFI0013-03	Fitting, 1/4 O.D. Tube x 1/8 NPT	1	2	2	3	1

\* See "Parts List Bullet Definition Table" below.

2 Install fitting hand-tight, then 1/4 turn with wrench.

1 Apply 59915-01 tape to all male pipe threads.

**RECOMMENDED SPARE PARTS**

Part #	Description	Qty
See Table B, "K" (Pg. 39)	Fluid Tube	1
79001-05	O-Ring, Solvent Resistant	3
LSFA0004-56C	Screw, 1/4-20 x 1.75 Long, Nyl., Fill Head	2
7554-03	O-Ring, Solvent Resistant	1
RPM-2	Shaping Air Cap Retainer	1
LSOR0005-01	O-Ring, Encapsulated	1
See Table A, "N" (Pg. 39)	Bell Cup Assembly	1
LSOR0005-02	O-Ring, Encapsulated	1
76917-00	Valve, Plastic Fluid	3
73913-00	Regulator Repair Kit, w/Solvent Resistant O-Rings	1
73913-01	Regulator Repair Kit, w/Solvent Proof O-Rings	1

**Figure 20: Recommended Spare Parts****SERVICE KITS**

Part #	Description
AER4019-00	Air Bearing Rebuild Kit
73913-00	Regulator Repair Kit, w/Solvent Resistant O-Rings
73913-01	Regulator Repair Kit, w/Solvent Proof O-Rings

**Figure 21: Service Kits****AVAILABLE TOOLS**

Part #	Description
RPM-419	Shroud Wrench
AER0076-01	Feed Tube Center Location Gauge

**Figure 22: Available Tools**



## APPENDIX

## PAINT AND SOLVENT SPECIFICATIONS

	REA® / EFM™	REM™ / M90	NO. 2 HAND GUN	TURBODISK™	AEROBELL™ II*** AEROBELL™ AEROBELL™ 33 RMA™-101
RECOMMENDED VISCOSITY USING A ZAHN NO. 2	18 TO 30 SEC	18 TO 30 SEC	20 TO 60 SEC	20 TO 60 SEC	20 TO 60 SEC
PAINT ELECTRICAL RESISTANCE**	.1 MΩ TO ∞	.1 MΩ TO ∞	.1 TO 1 MΩ	.1 MΩ TO ∞	.1 MΩ TO ∞
RECOMMENDED DELIVERY (UP TO)	1000 cc/min	1500 cc/min	180 cc/min	1000 cc/min	500 cc/min

## GUIDE TO USABLE SOLVENT SELECTION

Chemical Name	Common Name	Category	*CAS Number	Flash Point†† (TCC)	Evap. Rate†	Elec. Res.**
DICHLOROMETHANE	Methylene Chloride	Chlorinated Solvents	75-09-2		14.5	HIGH
MYTHYL ACETATE		Esters	79-20-9	90°F	5.3	LOW
VM & P NAPHTHA	Naptha	Aliphatic Hydrocarbons	803-232-4	65°F	10	HIGH
ACETONE		Ketones	67-64-1	-18°F	5.6	LOW
BENZENE		Aromatic Hydrocarbons	71-43-2	12°F	5.1	HIGH
ETHYL ACETATE		Esters	141-78-6	24°F	3.9	MEDIUM
2-BUTANONE	MEK	Ketones	78-93-3	16°F	3.8	MEDIUM
ISO-PROPYL ACETATE		Esters	108-21-4	35°F	3.4	LOW
ISOPROPYL ALCOHOL	IPA	Alcohols	67-63-0	53°F	2.5	LOW
2-PENTANONE	MPK	Ketones	107-87-9	104°F	2.5	MEDIUM
METHANOL	Methyl Alcohol	Alcohols	67-56-1	50°F	2.1	LOW
PROPYL ACETATE	n-Propyl Acetate	Esters	109-60-4	55°F	2.1	LOW
TOLUOL	Toluene	Aromatic Hydrocarbons	108-88-3	48°F	1.9	HIGH
METHYL ISOBUTYL KETONE	MIBK	Ketones	108-10-1	60°F	1.6	MEDIUM
ISOBUTYL ACETATE		Esters	110-19-0	69°F	1.5	LOW
ETHANOL	Ethyl Alcohol	Alcohols	64-17-5		1.4	LOW
<b>BUTYL ACETATE</b>		<b>Esters</b>	<b>123-86-4</b>	<b>78°F</b>	<b>1.0</b>	<b>LOW</b>
ETHYLBENZENE		Aromatic Hydrocarbons	100-41-4	64°F	.89	HIGH
1-PROPANOL	n-Propyl Alcohol	Alcohols	71-23-8	74°F	.86	LOW
2-BUTANOL	sec.-Butyl Alcohol	Alcohols	78-92-2	72°F	.81	LOW
XYLOL	Xylene	Aromatic Hydrocarbons	133-02-07	79°F	.80	HIGH
AMYL ACETATE		Esters	628-63-7	106°F	.67	MEDIUM
2-METHYLPROPANOL	iso-Butyl Alcohol	Alcohols	78-83-1	82°F	.62	LOW
METHYL AMYL ACETATE		Esters	108-84-9	96°F	.50	LOW
5-METHYL-2-HEXANONE	MIAK	Ketones	110-12-3	96°F	.50	MEDIUM
1-BUTANOL	n-Butyl Alcohol	Alcohols	71-36-3	95°F	.43	LOW
2-ETHOXYETHANOL		Glycol Ethers	110-80-5	164°F	.38	LOW
2-HEPTANONE	MAK	Ketones	110-43-0	102°F	.40	MEDIUM
CYCLOHEXANONE		Ketones	108-94-1	111°F	.29	MEDIUM
AROMATIC-100	SC#100	Aromatic Hydrocarbons		111°F	.20	HIGH
DIISOBUTYL KETONE	DIBK	Ketones	108-83-8	120°F	.19	MEDIUM
1-PENTANOL	Amyl Alcohol	Alcohols	71-41-0		.15	LOW
DIACETONE ALCOHOL		Ketones	123-42-2	133°F	.12	LOW
2-BUTOXYETHANOL	Butyl Cellosolve	Glycol Ethers	111-76-2	154°F	.07	LOW
CYCLOHEXANOL		Alcohols	108-93-0	111°F	.05	LOW
AROMATIC-150	SC#150	Aromatic Hydrocarbons		149°F	.004	HIGH
AROMATIC-200		Aromatic Hydrocarbons		203°F	.003	HIGH

\* CAS Number: Chemical Abstract Service Number.

\*\* Using the Ransburg Meter.

\*\*\* Solventborne Configuration Only.

† Information Obtained From: <http://solvdb.ncms.org>

Evaporation Rate is Based Upon Butyl Acetate Having a Rate of 1.0

NOTE: This page provides resistivity determination and control information that we feel is necessary when using Ransburg equipment.

© 2013 Ransburg

### VISCOSITY CONVERSION CHART

Poise	Centipoise	Parlin 7	Parlin 10	Fisher 1	Fisher 2	Ford Cup 3	Ford Cup 4	Gardner - Holdt Bubble	Gardner - Lithographic	Krebs Unit KU	Saybolt Universal SSU	Zahn 1	Zahn 2	Zahn 3	Zahn 4	Zahn 5	Sears Craftsman Cup	Din Cup 4
.1	10	27	11	20			5	A-4			60	30	16					10
.15	15	30	12	25			8	A-3			80	34	17					11
.2	20	32	13	30	15	12	10				100	37	18					12
.25	25	37	14	35	17	15	12	A-2			130	41	19					13
.3	30	43	15	39	18	19	14	A-1			160	44	20					14
.4	40	50	16	50	21	25	18	A			210	52	22				19	15
.5	50	57	17		24	29	22			30	260	60	24				20	16
.6	60	64	18		29	33	25	B		33	320	68	27				21	18
.7	70		20		33	36	28			35	370		30				23	21
.8	80		22		39	41	31	C		37	430		34				24	23
.9	90		23		44	45	32			38	480		37	10			26	25
1.0	100		25		50	50	34	D		40	530		41	12	10		27	27
1.2	120		30		62	58	41	E		43	580		49	14	11		31	31
1.4	140		32			66	45	F		46	690		58	16	13		34	34
1.6	160		37				50	G		48	790		66	18	14		38	38
1.8	180		41				54		000	50	900		74	20	16		40	43
2.0	200		45				58	H		52	1000		82	23	17	10	44	46
2.2	220						62	I		54	1100			25	18	11		51
2.4	240						65	J		56	1200			27	20	12		55
2.6	260						68			58	1280			30	21	13		58
2.8	280						70	K		59	1380			32	22	14		63
3.0	300						74	L		60	1475			34	24	15		68
3.2	320							M			1530			36	25	16		72
3.4	340							N			1630			39	26	17		76
3.6	360							O		62	1730			41	28	18		82
3.8	380										1850			43	29	19		86
4.0	400							P		64	1950			46	30	20		90
4.2	420										2050			48	32	21		95
4.4	440							Q			2160			50	33	22		100
4.6	460							R		66	2270			52	34	23		104
4.8	480								00	67	2380			54	36	24		109
5.0	500							S		68	2480			57	37	25		112
5.5	550							T		69	2660			63	40	27		124
6.0	600							U		71	2900			68	44	30		135
7.0	700									74	3375				51	35		160
8.0	800								0	77	3380				58	40		172
9.0	900							V		81	4300				64	45		195
10.0	1000							W		85	4600					49		218
11.0	1100									88	5200					55		
12.0	1200									92	5620					59		

(Continued On Next Page)

**VISCOSITY CONVERSION CHART (Cont.)**

Poise	Centipoise	Parlin 7	Parlin 10	Fisher 1	Fisher 2	Ford Cup 3	Ford Cup 4	Gardner - Holdt Bubble	Gardner - Lithographic	Krebs Unit KU	Saybolt Universal SSU	Zahn 1	Zahn 2	Zahn 3	Zahn 4	Zahn 5	Sears Craftsman Cup	Din Cup 4
13.0	1300							X			95	6100				64		
14.0	1400								1		96	6480						
15.0	1500										98	7000						
16.0	1600										100	7500						
17.0	1700										101	8000						
18.0	1800							Y				8500						
19.0	1900											9000						
20.0	2000										103	9400						
21.0	2100											9850						
22.0	2200											10300						
23.0	2300							Z	2		105	10750						
24.0	2400										109	11200						
25.0	2500							Z-1			114	11600						
30.0	3000										121	14500						
35.0	3500							Z-2	3		129	16500						
40.0	4000										133	18500						
45.0	4500							Z-3			136	21000						
50.0	5000											23500						
55.0	5500											26000						
60.0	6000							Z-4	4			2800						
65.0	6500											30000						
70.0	7000											32500						
75.0	7500											35000						
80.0	8000											37000						
85.0	8500											39500						
90.0	9000											41000						
95.0	9500											43000						
100.0	10000							Z-5	5			46500						
110.0	11000											51000						
120.0	12000											55005						
130.0	13000											60000						
140.0	14000											65000						
150.0	15000							Z-6				67500						
160.0	16000											74000						
170.0	17000											83500						
180.0	18000											83500						
190.0	19000											88000						
200.0	20000											93000						
300.0	30000											140000						

**Note:** All viscosity comparisons are as accurate as possible with existing information. Comparisons are made with a material having a specific gravity of 1.0.

### VOLUMETRIC CONTENT OF HOSE OR TUBE (English Units)

I.D. (inches)	cc/ft.	Cross Section (sq. in.)	Length				
			5ft. (60")	10ft. (120")	15ft. (180")	25ft. (300")	50ft. (600")
1/8	2.4	.012	.003 gal. .4 fl. oz.	.006 gal. .8 fl. oz.	.010 gal. 1.2 fl. oz.	.016 gal. 2.0 fl. oz.	.03 gal. 4.1 fl. oz.
3/16	5.4	.028	.007 gal. .9 fl. oz.	.014 gal. 1.8 fl. oz.	.022 gal. 2.8 fl. oz.	.036 gal. 4.6 fl. oz.	.072 gal. 9.2 fl. oz.
1/4	9.7	.049	.013 gal. 1.6 fl. oz.	.025 gal. 3.3 fl. oz.	.038 gal. 4.9 fl. oz.	.064 gal. 8.2 fl. oz.	.127 gal. 16.3 fl. oz.
5/16	15.1	.077	.020 gal. 2.5 fl. oz.	.040 gal. 5.1 fl. oz.	.060 gal. 7.6 fl. oz.	.100 gal. 12.7 fl. oz.	.199 gal. 25.5 fl. oz.
3/8	21.7	.110	.029 gal. 3.7 fl. oz.	.057 gal. 7.3 fl. oz.	.086 gal. 11.0 fl. oz.	.143 gal. 18.4 fl. oz.	.287 gal. 36.7 fl. oz.
1/2	38.6	.196	.051 gal. 6.5 fl. oz.	.102 gal. 13.1 fl. oz.	.153 gal. 19.6 fl. oz.	.255 gal. 3.6 fl. oz.	.510 gal. 65.3 fl. oz.

### VOLUMETRIC CONTENT OF HOSE OR TUBE (Metric Units)

I.D. (mm)	cc/mm	Cross Section (mm <sup>2</sup> )	Length				
			1.5m	3.0m	4.5m	6.0m	7.5m
3.6	10.2	10.2	15.3 cc	30.5 cc	45.8 cc	61.1 cc	76.3 cc
5.6	24.6	24.6	36.9 cc	73.9 cc	110.8 cc	147.8 cc	184.7 cc
6.8	36.3	36.3	54.5 cc	109.0 cc	163.4 cc	217.9 cc	272.4 cc
8.8	60.8	60.8	91.2 cc	182.5 cc	273.7 cc	364.9 cc	456.2 cc

# MANUAL CHANGE SUMMARY

## LN-9521-00-R5 - Replaces LN-9521-00 with the following changes:

No.	Change Description	Page(s)
1.	Update to current format	All
2.	Remove comas from "High Voltage Cables" text	11
3.	Update "SPECIFICATIONS" text	12
4.	Create new graphs	13-15
5.	Add text to bullet point 2	16
6.	Add specs to "MOUNTING" text	17
7.	Update text to bullet points in first column	19
8.	Create new graphs for figures 12a and 12b	21
9.	Update specs in paragraph 2 in "BEARING AIR ADJUSTMENT" and paragraph 1 of the next page	22-23
10.	Add specs to "TARGET DISTANCE" text	23
11.	Change part number under "HIGH VOLTAGE CONNECTIONS" and correct part number under "PREVENTIVE MAINTENANCE"	26
12.	Correct part number under "PREVENTIVE MAINTENANCE"	27
13.	Add spec to second bullet point in the first column	27
14.	Add spec to first paragraph and remove last bullet point in the first column	28
15.	Make updates to "BELL CUP CLEANING" text	28-29
16.	Make numerous updates to text	31-33
17.	Update text for "TROUBLESHOOTING GUIDE" under "Solution"	35-36
18.	Update text for tables A through E	39-40
19.	Update text for "AEROBELL 33 - PARTS LIST"	41
20.	Update table head and call-out number 6 in the drawing	42-43
21.	Update "FLUID MANIFOLD ASSEMBLY" table	45
22.	Update "RECOMMENDED SPARE PARTS" text	48

## WARRANTY POLICY

This product is covered by Carlisle Fluid Technologies materials and workmanship limited warranty. The use of any parts or accessories, from a source other than Carlisle Fluid Technologies, will void all warranties. For specific warranty information please contact Carlisle Fluid Technologies.

Carlisle Fluid Technologies is a global leader in innovative finishing technologies. Carlisle Fluid Technologies reserves the right to modify equipment specifications without prior notice.

DeVilbiss®, Ransburg®, MS®, BGK®, and Binks®,  
are registered trademarks of Carlisle Fluid Technologies, Inc.

©2020 Carlisle Fluid Technologies, Inc.  
All rights reserved.

For technical assistance or to locate an authorized distributor, contact one of our international sales and customer support locations.

<b>Region</b>	<b>Industrial / Automotive</b>	<b>Automotive Refinishing</b>
<b>Americas</b>	Tel: 1-800-992-4657 Fax: 1-888-246-5732	Tel: 1-800-445-3988 Fax: 1-800-445-6643
<b>Europe, Africa Middle East, India</b>	Tel: +44 (0)1202 571 111 Fax: +44 (0)1202 573 488	
<b>China</b>	Tel: +8621-3373 0108 Fax: +8621-3373 0308	
<b>Japan</b>	Tel: +81 45 785 6421 Fax: +81 45 785 6517	
<b>Australia</b>	Tel: +61 (0) 2 8525 7555 Fax: +61 (0) 2 8525 7575	

For the latest information about our products, visit [www.carlisleft.com](http://www.carlisleft.com).