

SERVICE & OPERATING MANUAL

Original Instructions

Certified Quality



Quality System
ISO9001 Certified



Environmental Management System
ISO14001 Certified



Binks

195 International Blvd.,
Glendale Heights, IL 60139 USA

Telephone:
1.800.99.BINKS
630.237.5000

Toll Free Customer Service
and Technical Support
800-992-4657

Toll Free Fax
888-246-5732

Model 41-818820

Model 41-818820-B

Model 41-818822

Model 41-818823-B

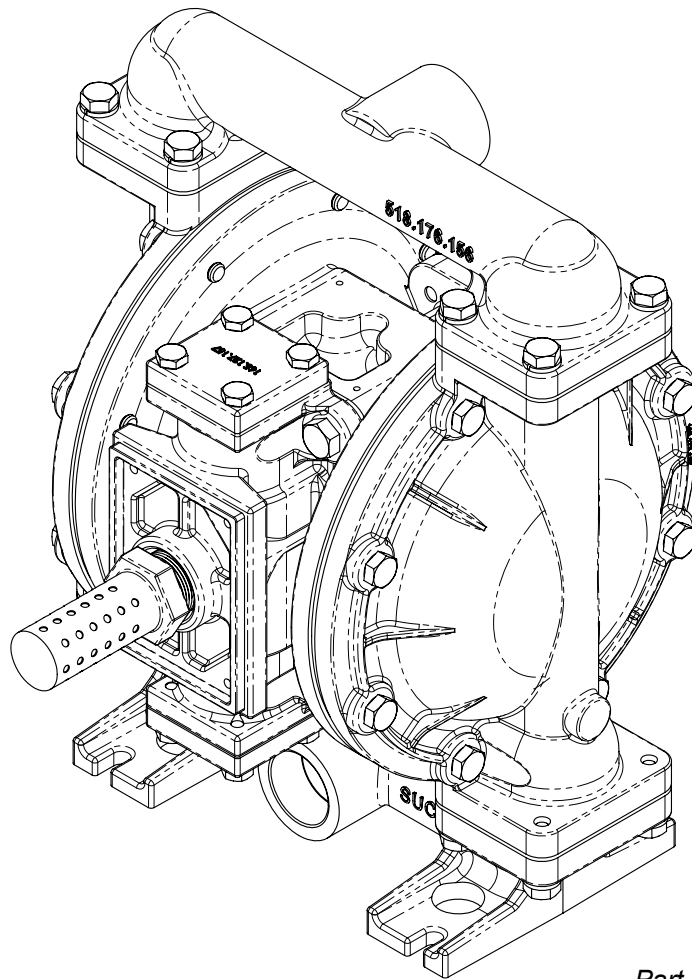

Part Sheet 77-2994

BINKS[®]
GEMINI™ II SERIES

1: PUMP SPECS

2: INSTAL & OP

3: EXP VIEW

4: AIR END

5: WET END

6: CERTIFICATES

Safety Information

IMPORTANT



Read the safety warnings and instructions in this manual before pump installation and start-up. Failure to comply with the recommendations stated in this manual could damage the pump and void factory warranty.



When the pump is used for materials that tend to settle out or solidify, the pump should be flushed after each use to prevent damage. In freezing temperatures the pump should be completely drained between uses.

CAUTION



Before pump operation, inspect all fasteners for loosening caused by gasket creep. Retighten loose fasteners to prevent leakage. Follow recommended torques stated in this manual.



Nonmetallic pumps and plastic components are not UV stabilized. Ultraviolet radiation can damage these parts and negatively affect material properties. Do not expose to UV light for extended periods of time.



WARNING

Pump not designed, tested or certified to be powered by compressed natural gas. Powering the pump with natural gas will void the warranty.

WARNING



When used for toxic or aggressive fluids, the pump should always be flushed clean prior to disassembly.



Before maintenance or repair, shut off the compressed air line, bleed the pressure, and disconnect the air line from the pump. Be certain that approved eye protection and protective clothing are worn at all times. Failure to follow these recommendations may result in serious injury or death.



Airborne particles and loud noise hazards. Wear eye and ear protection.



In the event of diaphragm rupture, pumped material may enter the air end of the pump, and be discharged into the atmosphere. If pumping a product that is hazardous or toxic, the air exhaust must be piped to an appropriate area for safe containment.



Take action to prevent static sparking. Fire or explosion can result, especially when handling flammable liquids. The pump, piping, valves, containers and other miscellaneous equipment must be properly grounded.



This pump is pressurized internally with air pressure during operation. Make certain that all fasteners are in good condition and are reinstalled properly during reassembly.



Use safe practices when lifting

Grounding ATEX Pumps

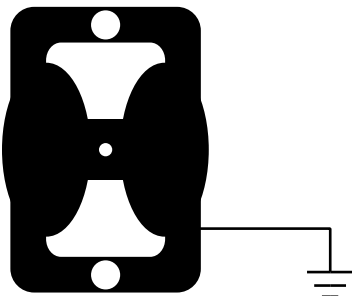

ATEX compliant pumps are suitable for use in explosive atmospheres when the equipment is properly grounded in accordance with local electrical codes. Pumps equipped with electrically conductive diaphragms are suitable for the transfer of conductive or non-conductive fluids of any explosion group. When operating pumps equipped with non-conductive diaphragms that exceed the maximum permissible projected area, as defined in EN 13461-1: 2009 section 6.7.5 table 9, the following protection methods must be applied:

- Equipment is always used to transfer electrically conductive fluids or
- Explosive environment is prevented from entering the internal portions of the pump, i.e. dry running

For further guidance on ATEX applications, please consult the factory.

Table of Contents

SECTION 1: PUMP SPECIFICATIONS.....1

- Performance
- Materials
- Dimensional Drawings

SECTION 2: INSTALLATION & OPERATION.....3

- Principle of Pump Operation
- Recommended Installation Guide
- Troubleshooting Guide

SECTION 3: EXPLODED VIEW.....6

- Composite Repair Parts Drawing
- Composite Repair Parts List

SECTION 4: AIR END.....8

- Air Distribution Valve Assembly
- Pilot Valve Assembly
- Intermediate Assembly

SECTION 5: WET END11

- Diaphragm Drawings
- Diaphragm Servicing

SECTION 6: CERTIFICATES13

- Warranty and Contact Information
- EC Declaration of Conformity - Machinery
- EC Declaration of Conformity - ATEX

1: PUMP SPECS

2: INSTAL & OP

3: EXP VIEW

4: AIR END

5: WET END

6: CERTIFICATES

Performance

SUCTION/DISCHARGE PORT SIZE

- Model 41-818820 & 41-818822
1" NPT (internal)
- Model 41-818820-B & 41-818823-B
1" BSP Tapered (internal)

CAPACITY

- 0 to 45 gallons per minute
(0 to 170 liters per minute)

AIR DISTRIBUTION VALVE

- No-lube, no-stall design

SOLIDS-HANDLING

- Up to .25 in. (6mm)

HEADS UP TO

- 125 psi or 289 ft. of water
(8.6 Kg/cm² or 86 meters)

DISPLACEMENT/STROKE

- .11 Gallon / .42 liter

MAXIMUM OPERATING PRESSURE

- 125 psi (8.6 bar)

SHIPPING WEIGHT

- Aluminum 28 lbs. (13kg)
- Stainless Steel 43 lbs. (20kg)

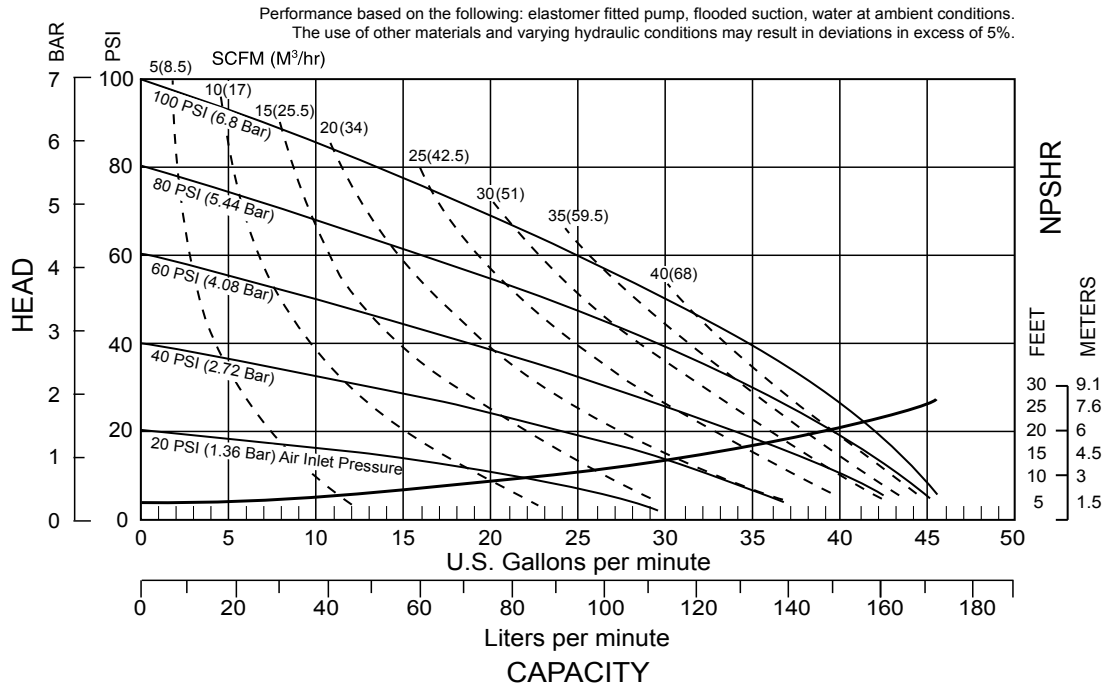

Materials

Material Profile:

CAUTION! Operating temperature limitations are as follows:

Nitrile: General purpose, oil-resistant. Shows good solvent, oil, water and hydraulic fluid resistance. Should not be used with highly polar solvents like acetone and MEK, ozone, chlorinated hydrocarbons and nitro hydrocarbons.

Santoprene®: Injection molded thermoplastic elastomer with no fabric layer. Long mechanical flex life. Excellent abrasion resistance.

Virgin PTFE: (PFA/TFE) Chemically inert, virtually impervious. Very few chemicals are known to chemically react with PTFE; molten alkali metals, turbulent liquid or gaseous fluorine and a few fluoro-chemicals such as chlorine trifluoride or oxygen difluoride which readily liberate free fluorine at elevated temperatures.

Maximum and Minimum Temperatures are the limits for which these materials can be operated. Temperatures coupled with pressure affect the longevity of diaphragm pump components. Maximum life should not be expected at the extreme limits of the temperature ranges.

Metals:

Stainless Steel: Equal to or exceeding ASTM specification A743 CF-8M for corrosion resistant iron chromium, iron chromium nickel and nickel based alloy castings for general applications. Commonly referred to as 316 Stainless Steel in the pump industry.

Ambient temperature range: -20°C to +40°C

Process temperature range: -20°C to +100°C for models rated as category 2 equipment

Dimensional Drawings

Dimensions in Inches. Dimensional Tolerance: $\pm 1/8"$

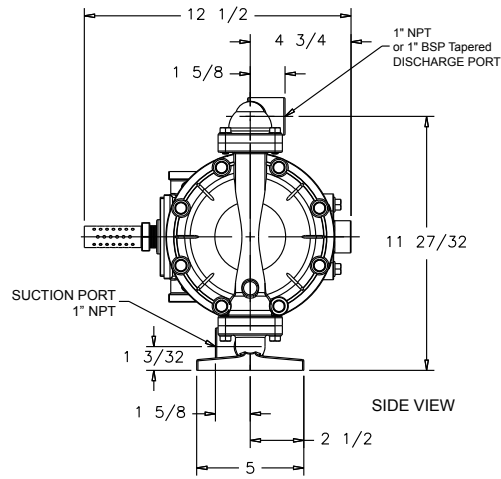
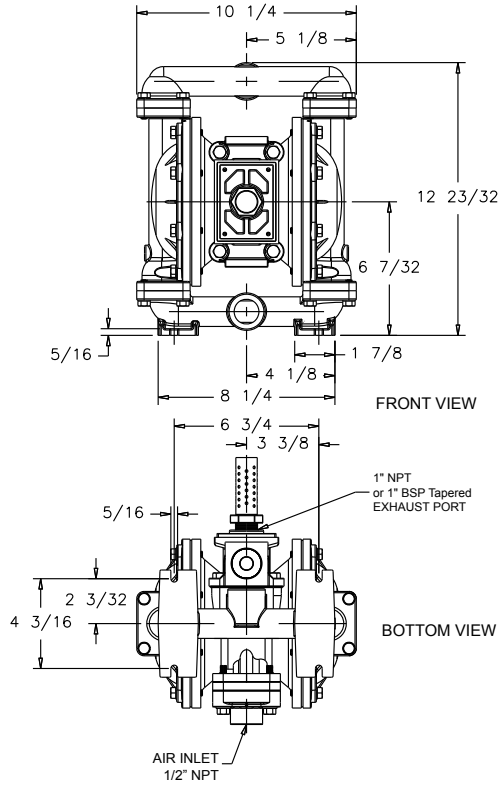

BOTH SUCTION AND DISCHARGE PORTS ARE AVAILABLE WITH 1" BSPT TAPERED THREADS (41-818823 STAINLESS STEEL ONLY)

Dimensions in Millimeters. Dimensional Tolerance: $\pm 3\text{mm}$

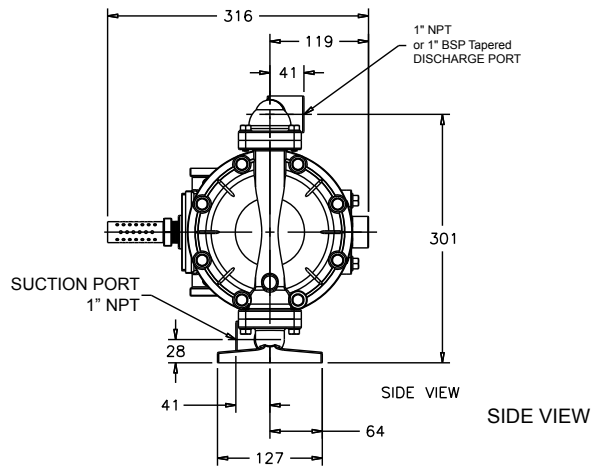
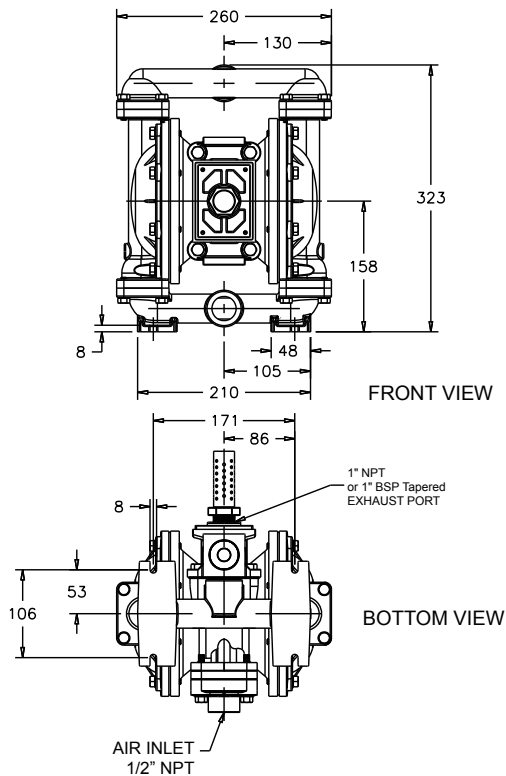

BOTH SUCTION AND DISCHARGE PORTS ARE AVAILABLE WITH 1" BSPT TAPERED THREADS (41-818823 STAINLESS STEEL ONLY)

Principle of Pump Operation

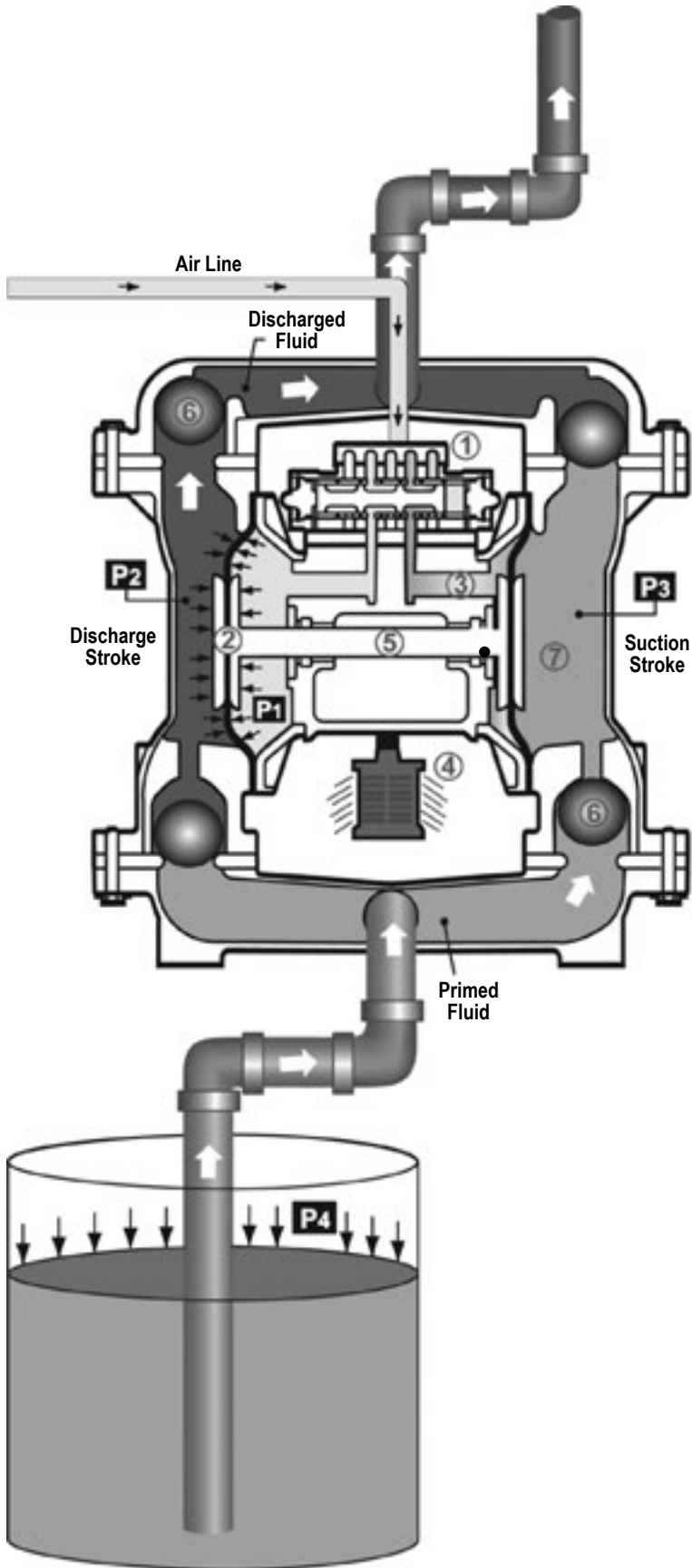

Air-Operated Double Diaphragm (AODD) pumps are powered by compressed air.

The main directional (air) control valve ① distributes compressed air to an air chamber, exerting uniform pressure over the inner surface of the diaphragm ②. At the same time, the exhausting air ③ from behind the opposite diaphragm is directed through the air valve assembly(s) to an exhaust port ④.

As inner chamber pressure (P1) exceeds liquid chamber pressure (P2), the rod ⑤ connected diaphragms shift together creating discharge on one side and suction on the opposite side. The discharged and primed liquid's directions are controlled by the check valves (ball or flap)⑥ orientation.

The pump primes as a result of the suction stroke. The suction stroke lowers the chamber pressure (P3) increasing the chamber volume. This results in a pressure differential necessary for atmospheric pressure (P4) to push the fluid through the suction piping and across the suction side check valve and into the outer fluid chamber ⑦.

Suction (side) stroking also initiates the reciprocating (shifting, stroking or cycling) action of the pump. The suction diaphragm's movement is mechanically pulled through its stroke. The diaphragm's inner plate makes contact with an actuator plunger aligned to shift the pilot signaling valve. Once actuated, the pilot valve sends a pressure signal to the opposite end of the main directional air valve, redirecting the compressed air to the opposite inner chamber.

Recommended Installation Guide

Installation And Start-Up

Locate the pump as close to the product being pumped as possible. Keep the suction line length and number of fittings to a minimum. Do not reduce the suction line diameter.

Air Supply

Connect the pump air inlet to an air supply with sufficient capacity and pressure to achieve desired performance. A pressure regulating valve should be installed to insure air supply pressure does not exceed recommended limits.

Air Valve Lubrication

The air distribution system is designed to operate WITHOUT lubrication. This is the standard mode of operation. If lubrication is desired, install an air line lubricator set to deliver one drop of SAE 10 non-detergent oil for every 20 SCFM (9.4 liters/sec.) of air the pump consumes. Consult the Performance Curve to determine air consumption.

Air Line Moisture

Water in the compressed air supply may cause icing or freezing of the exhaust air, causing the pump to cycle erratically or stop operating. Water in the air supply can be reduced by using a point-of-use air dryer.

Air Inlet And Priming

To start the pump, slightly open the air shut-off valve. After the pump primes, the air valve can be opened to increase air flow as desired. If opening the valve increases cycling rate, but does not increase the rate of flow, cavitation has occurred. The valve should be closed slightly to obtain the most efficient air flow to pump flow ratio.

Troubleshooting Guide

Symptom:	Potential Cause(s):	Recommendation(s):
Pump Cycles Once	Deadhead (system pressure meets or exceeds air supply pressure).	Increase the inlet air pressure to the pump. Pump is designed for 1:1 pressure ratio at zero flow. (Does not apply to high pressure 2:1 units).
	Air valve or intermediate gaskets installed incorrectly.	Install gaskets with holes properly aligned.
	Bent or missing actuator plunger.	Remove pilot valve and inspect actuator plungers.
Pump Will Not Operate / Cycle	Pump is over lubricated.	Set lubricator on lowest possible setting or remove. Units are designed for lube free operation.
	Lack of air (line size, PSI, CFM).	Check the air line size and length, compressor capacity (HP vs. CFM required).
	Check air distribution system.	Disassemble and inspect main air distribution valve, pilot valve and pilot valve actuators.
	Discharge line is blocked or clogged manifolds.	Check for inadvertently closed discharge line valves. Clean discharge manifolds/piping.
	Deadhead (system pressure meets or exceeds air supply pressure).	Increase the inlet air pressure to the pump. Pump is designed for 1:1 pressure ratio at zero flow. (Does not apply to high pressure 2:1 units).
	Blocked air exhaust muffler.	Remove muffler screen, clean or de-ice, and re-install.
	Pumped fluid in air exhaust muffler.	Disassemble pump chambers. Inspect for diaphragm rupture or loose diaphragm plate assembly.
	Pump chamber is blocked.	Disassemble and inspect wetted chambers. Remove or flush any obstructions.
Pump Cycles and Will Not Prime or No Flow	Cavitation on suction side.	Check suction condition (move pump closer to product).
	Check valve obstructed. Valve ball(s) not seating properly or sticking.	Disassemble the wet end of the pump and manually dislodge obstruction in the check valve pocket. Clean out around valve ball cage and valve seat area. Replace valve ball or valve seat if damaged. Use heavier valve ball material.
	Valve ball(s) missing (pushed into chamber or manifold).	Worn valve ball or valve seat. Worn fingers in valve ball cage (replace part). Check Chemical Resistance Guide for compatibility.
	Valve ball(s) / seat(s) damaged or attacked by product.	Check Chemical Resistance Guide for compatibility.
	Check valve and/or seat is worn or needs adjusting.	Inspect check valves and seats for wear and proper setting. Replace if necessary.
	Suction line is blocked.	Remove or flush obstruction. Check and clear all suction screens or strainers.
	Excessive suction lift.	For lifts exceeding 20' of liquid, filling the chambers with liquid will prime the pump in most cases.
	Suction side air leakage or air in product.	Visually inspect all suction-side gaskets and pipe connections.
Pump Cycles Running Sluggish / Stalling, Flow Unsatisfactory	Pumped fluid in air exhaust muffler.	Disassemble pump chambers. Inspect for diaphragm rupture or loose diaphragm plate assembly.
	Over lubrication.	Set lubricator on lowest possible setting or remove. Units are designed for lube free operation.
	Icing.	Remove muffler screen, de-ice, and re-install. Install a point of use air drier.
	Clogged manifolds.	Clean manifolds to allow proper air flow.
	Deadhead (system pressure meets or exceeds air supply pressure).	Increase the inlet air pressure to the pump. Pump is designed for 1:1 pressure ratio at zero flow. (Does not apply to high pressure 2:1 units).
	Cavitation on suction side.	Check suction (move pump closer to product).
	Lack of air (line size, PSI, CFM).	Check the air line size, length, compressor capacity.
	Excessive suction lift.	For lifts exceeding 20' of liquid, filling the chambers with liquid will prime the pump in most cases.
	Air supply pressure or volume exceeds system hd.	Decrease inlet air (press. and vol.) to the pump. Pump is cavitating the fluid by fast cycling.
	Undersized suction line.	Meet or exceed pump connections.
	Restrictive or undersized air line.	Install a larger air line and connection.
	Suction side air leakage or air in product.	Visually inspect all suction-side gaskets and pipe connections.
	Suction line is blocked.	Remove or flush obstruction. Check and clear all suction screens or strainers.
	Pumped fluid in air exhaust muffler.	Disassemble pump chambers. Inspect for diaphragm rupture or loose diaphragm plate assembly.
	Product Leaking Through Exhaust	Check valve obstructed.
Check valve and/or seat is worn or needs adjusting.		Inspect check valves and seats for wear and proper setting. Replace if necessary.
Entrained air or vapor lock in chamber(s).		Purge chambers through tapped chamber vent plugs. Purging the chambers of air can be dangerous.
Premature Diaphragm Failure	Diaphragm failure, or diaphragm plates loose.	Replace diaphragms, check for damage and ensure diaphragm plates are tight.
	Diaphragm stretched around center hole or bolt holes.	Check for excessive inlet pressure or air pressure. Consult Chemical Resistance Chart for compatibility with products, cleaners, temperature limitations and lubrication.
	Cavitation.	Enlarge pipe diameter on suction side of pump.
	Excessive flooded suction pressure.	Move pump closer to product. Raise pump/place pump on top of tank to reduce inlet pressure. Install Back pressure device (Tech bulletin 41r). Add accumulation tank or pulsation dampener.
Unbalanced Cycling	Misapplication (chemical/physical incompatibility).	Consult Chemical Resistance Chart for compatibility with products, cleaners, temperature limitations and lubrication.
	Incorrect diaphragm plates or plates on backwards, installed incorrectly or worn.	Check Operating Manual to check for correct part and installation. Ensure outer plates have not been worn to a sharp edge.
	Excessive suction lift.	For lifts exceeding 20' of liquid, filling the chambers with liquid will prime the pump in most cases.
	Undersized suction line.	Meet or exceed pump connections.
	Pumped fluid in air exhaust muffler.	Disassemble pump chambers. Inspect for diaphragm rupture or loose diaphragm plate assembly.
	Suction side air leakage or air in product.	Visually inspect all suction-side gaskets and pipe connections.
	Check valve obstructed.	Disassemble the wet end of the pump and manually dislodge obstruction in the check valve pocket.
Check valve and/or seat is worn or needs adjusting.	Inspect check valves and seats for wear and proper setting. Replace if necessary.	
Unbalanced Cycling	Entrained air or vapor lock in chamber(s).	Purge chambers through tapped chamber vent plugs.



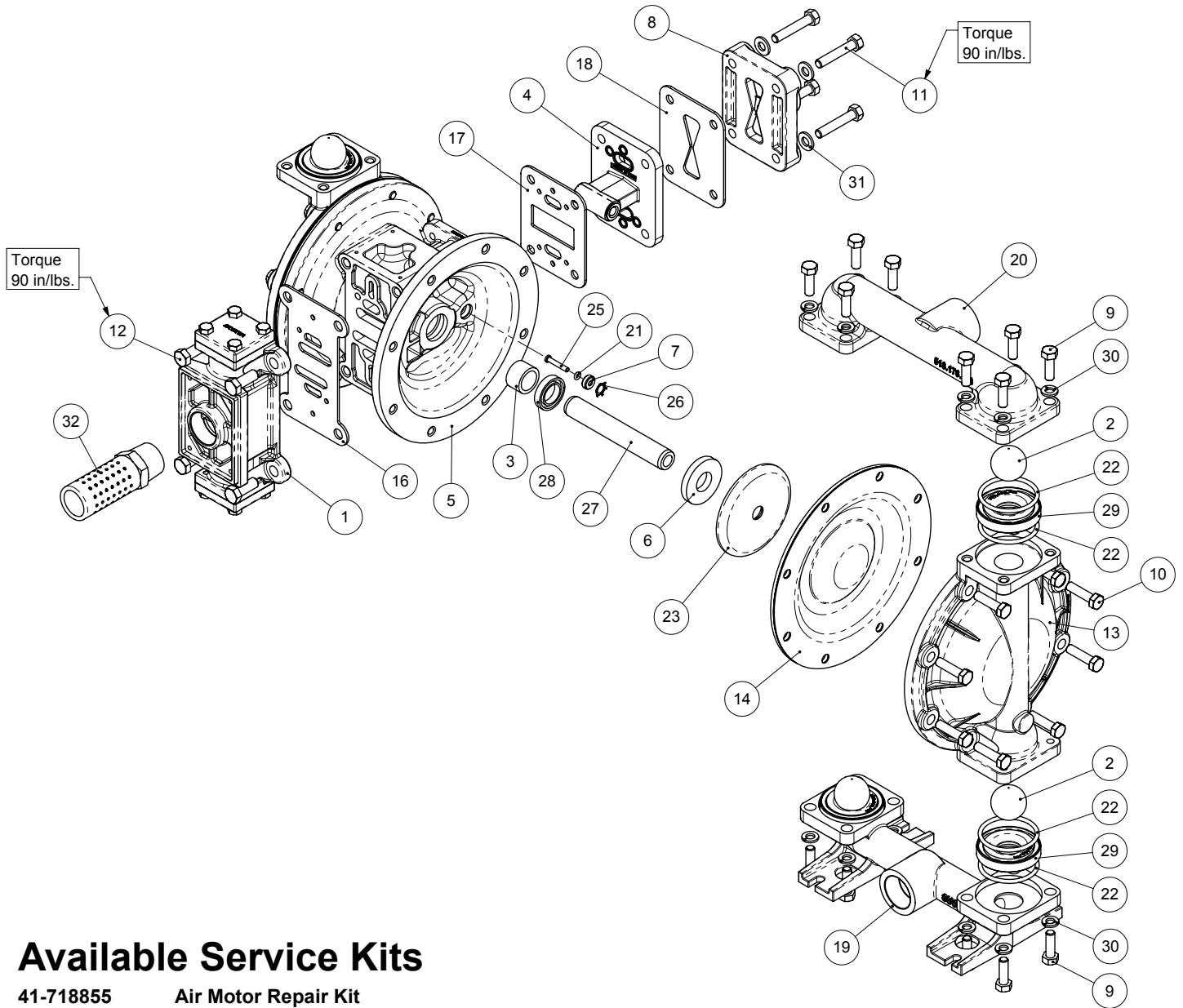







Composite Repair Parts Drawing



Available Service Kits

- 41-718855 Air Motor Repair Kit**
Bumpers, Bushings, Gaskets, O-rings, Retaining Rings, and Seals
- 41-718856 Diaphragm Kits**
Synthesis One-Piece Diaphragms, PTFE Manifolds O-rings, FEP - Encapsulated FKM O-rings for metal check valve seats
- 41-718857 Ball and Seat Kit**
316 Stainless Steel Check Balls, 316 Stainless Steel Check Valve Seats, FEP-Encapsulated FKM O-rings for metal check valve seats

Composite Repair Parts List

Item	Description	Qty
1	Air Valve Assembly	1
 2	Ball, Check	4
4	Pilot Valve Assembly	1
5	Intermediate	1
 6	Bumper	2
 7	Bushing	2
8	Cap, Air Inlet Assembly	1
9	Capscrew, Hex Hd 5/16-18 X 1.00	16
10	Capscrew, Hex Hd 5/16-18 X 1.25	16
11	Capscrew, Hex Hd 5/16-18 X 1.75	4
12	Capscrew, Hex HD 3/8-16 X 1.00	4
13	Chamber, Outer	2
 14	Diaphragm, Synthesis One-Piece	2
 16	Gasket, Air Valve	1
 17	Gasket, Pilot Valve	1
 18	Gasket, Air Inlet Cap	1
19	Manifold, Suction	1
20	Manifold, Discharge	1
21	O-Ring	2
22	O-Ring	8
 23	Plate, Inner Diaphragm	2
25	Pin, Actuator	2
26	Ring, Retaining	2
27	Rod, Diaphragm	1
28	Seal, U-Cup	2
 29	Seat, Check Ball	4
30	Lock Washer, 5/16	16
 31	Flat Washer, 5/16	4
 32	Muffler, Metal	1

3: EXP VIEW

LEGEND:

 = Items contained within 41-718855 Air Motor Repair Kits

 = Items contained within 41-718856 Diaphragm Kits

 = Items contained within 41-718857 Ball and Seat Kits

Air Distribution Valve Assembly

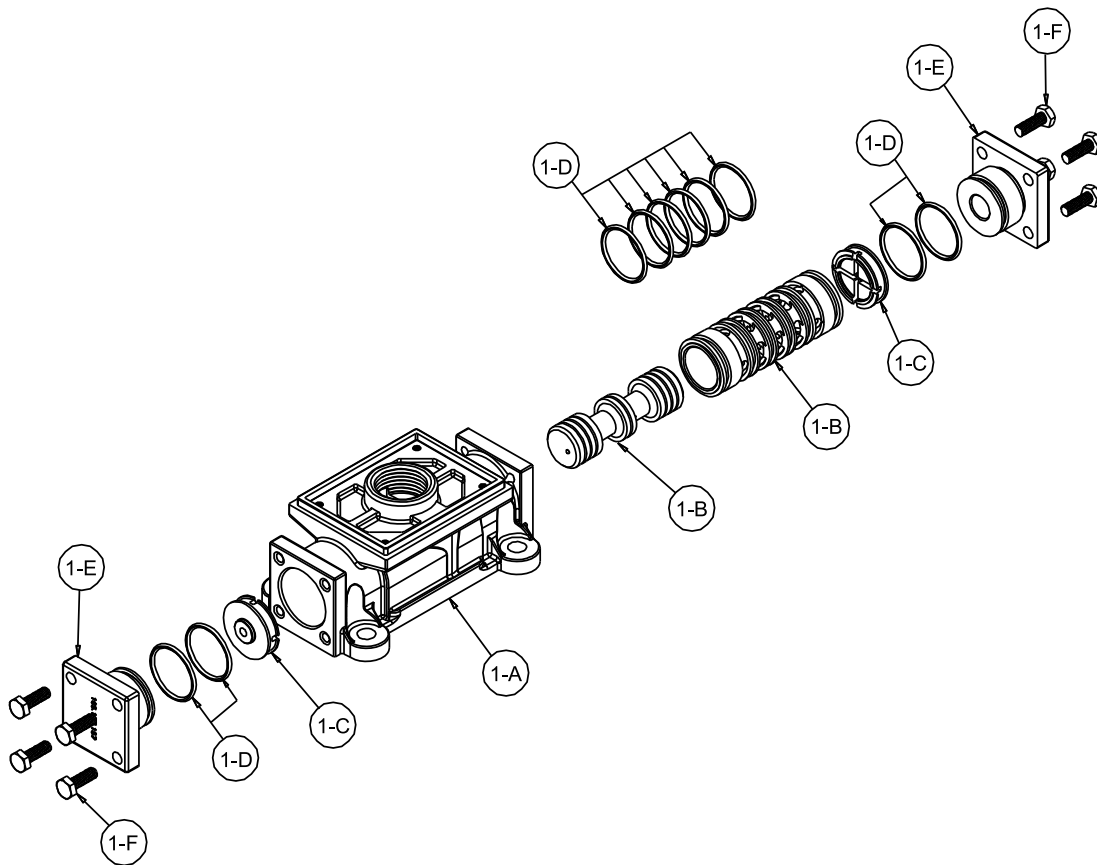

Air Distribution Valve Servicing

See repair parts drawing, remove screws.

Step 1: Remove hex cap screws (1-F).

Step 2: Remove end cap (1-E) and bumper (1-C).

Step 3: Remove spool part of (1-B) (caution: do not scratch).

Step 4: Press sleeve (1-B) from body (1-A).

Step 5: Inspect O-Rings (1-D) and replace if necessary.

Step 6: Lightly lubricate O-Rings (1-D) on sleeve (1-B).

Step 7: Press sleeve (1-B) into body (1-A).

Step 8: Reassemble in reverse order, starting with step 3.

Note: Sleeve and spool (1-B) set is match ground to a specified clearance sleeve and spools (1-B) cannot be interchanged.

Air Valve Assembly Parts List

Item	Description	Qty
1	Air Valve Assembly	1
1-A	Body, Air Valve	1
1-B	Sleeve and Spool Set	1
1-C	Bumper	2
1-D	O-Ring	10
1-E	Cap, End	2
1-F	Hex Head Capscrew 1/4-20 x .75	8

LEGEND:

○ = Items contained within 41-718850 Air Motor Repair Kits

IMPORTANT



Read these instructions completely, before installation and start-up. It is the responsibility of the purchaser to retain this manual for reference. Failure to comply with the recommendations stated in this manual will damage the pump, and void factory warranty.

Pilot Valve Assembly

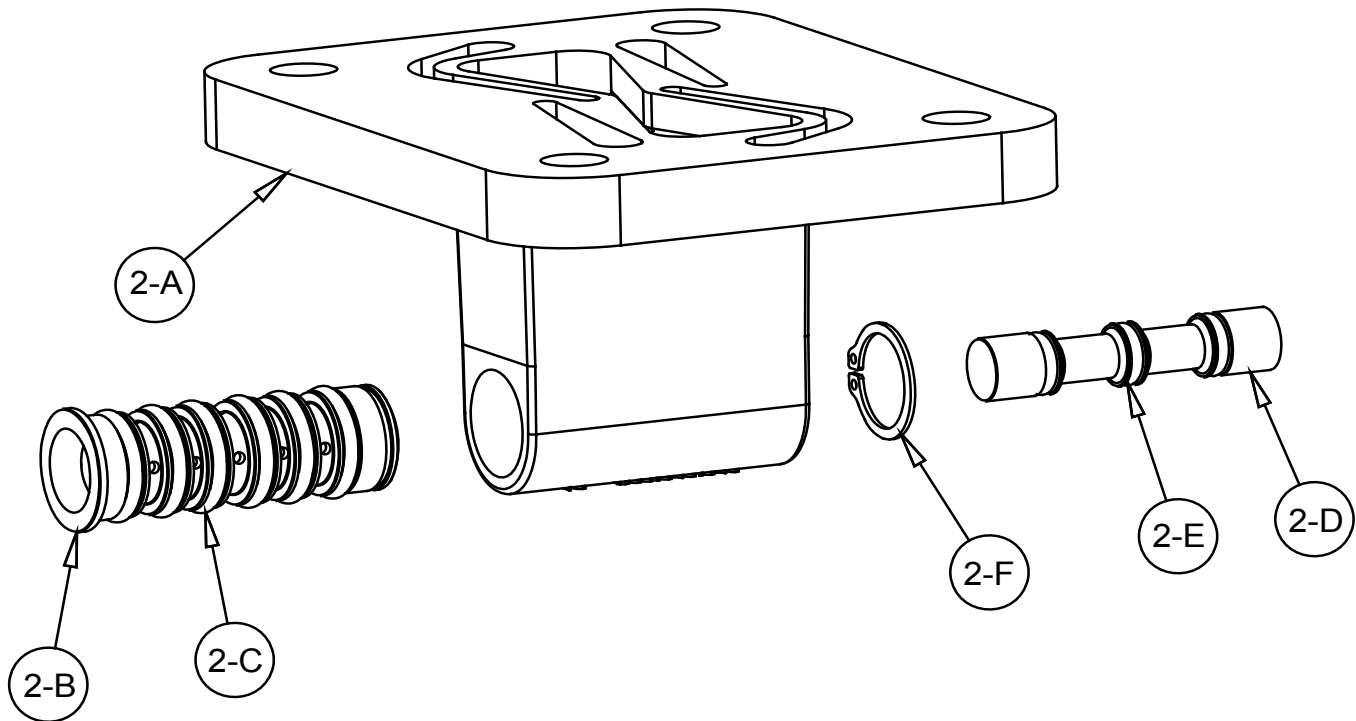

4: AIR END

Pilot Valve Servicing

With Pilot Valve removed from pump.

Step 1: Remove snap ring (4-F).

Step 2: Remove sleeve (4-B), inspect O-Rings (4-C), replace if required.

Step 3: Remove spool (4-D) from sleeve (4-B), inspect O-Rings (4-E), replace if required.

Step 4: Lightly lubricate O-Rings (4-C) and (4-E).

Reassemble in reverse order.

Pilot Valve Assembly Parts List

Item	Description	Qty
4	Pilot Valve Assembly	1
4-A	Valve Body	1
4-B	Sleeve (With O-Rings)	1
④-C	O-Ring (Sleeve)	6
4-D	Spool (With O-Rings)	1
④-E	O-Ring (Spool)	3
4-F	Retaining Ring	1

LEGEND:

○ = Items contained within 41-718850 Air Motor Repair Kits

Intermediate Assembly

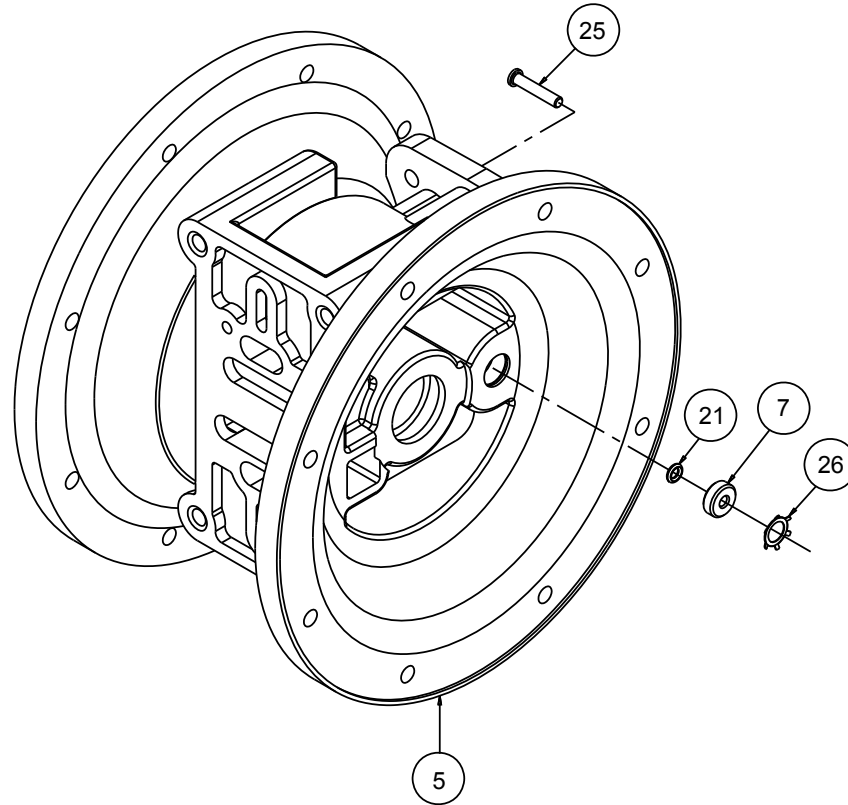

Intermediate Assembly Drawing

- Step 1:** Remove plunger, actuator (25) from center of intermediate pilot valve cavity.
- Step 2:** Remove Ring, Retaining (26), discard.
- Step 3:** Remove bushing, plunger (7), inspect for wear and replace if necessary with genuine parts.
- Step 4:** Remove O-Ring (21), inspect for wear and replace if necessary with genuine parts.
- Step 5:** Lightly lubricate O-Ring (21) and insert into intermediate.
- Step 6:** Utilizing a new Ring, Retaining (26) reassemble in reverse order
- Step 7:** Remove Seal, Diaphragm Rod (28).
- Step 8:** Clean seal area, lightly lubricate and install new Seal, Diaphragm Rod (28).

Intermediate Assembly Parts List

Item	Description	Qty
5	Intermediate	1
	Intermediate	1
7	Bushing, Plunger*	2
21	O-Ring	2
25	Plunger, Actuator*	2
26	Ring, Retaining	2
28	Seal, Diaphragm Rod*	2

LEGEND:

○ = Items contained within 41-718850 Air Motor Repair Kits

! IMPORTANT



When the pumped product source is at a higher level than the pump (flooded suction condition), pipe the exhaust higher than the product source to prevent siphoning spills. In the event of a diaphragm failure a complete rebuild of the center section is recommended.

Diaphragm Service Drawing, with Overlay

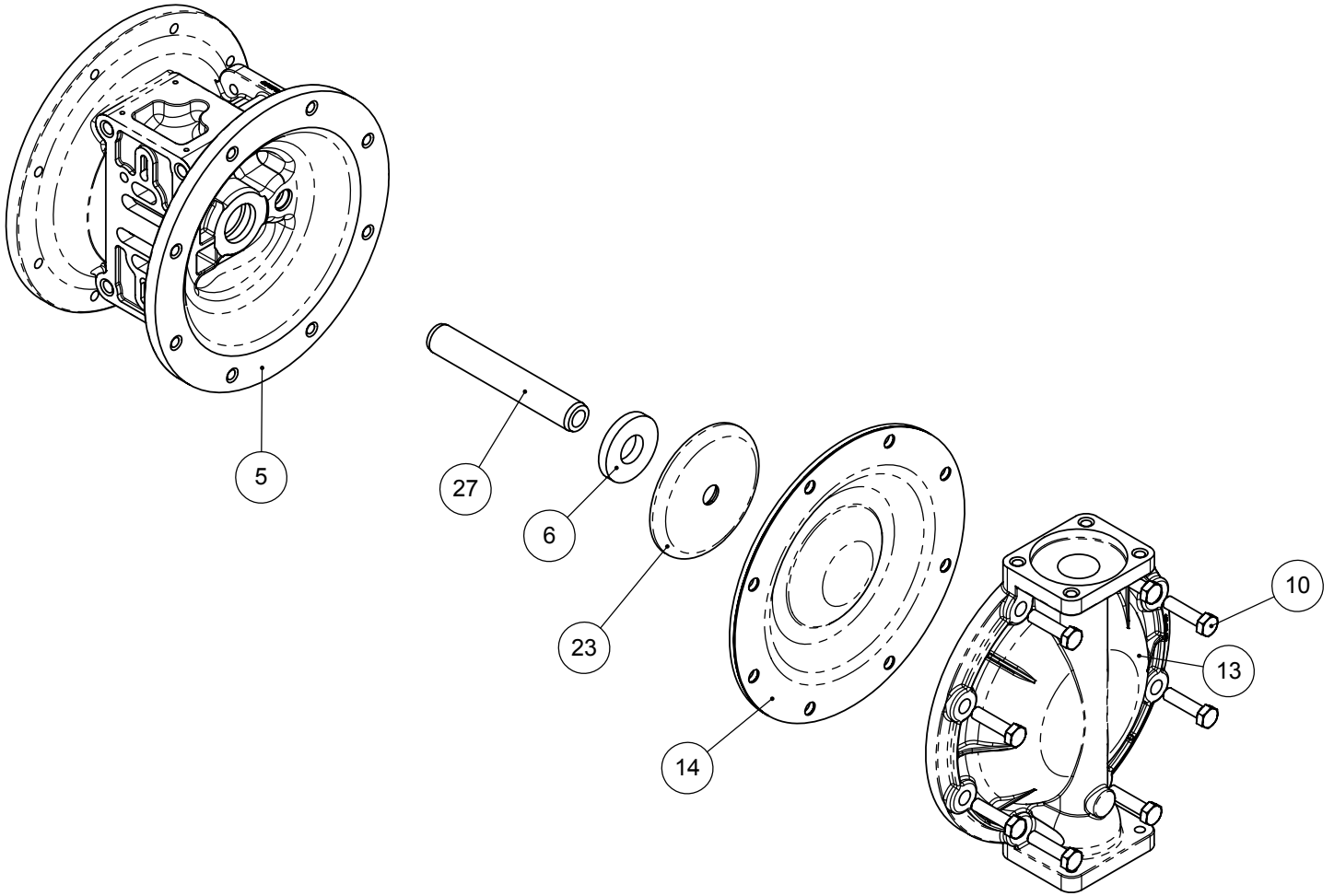

5: WET END

Diaphragm Servicing

Step 1: With manifolds and outer chambers removed, remove diaphragm assemblies from diaphragm rod. **DO NOT** use a pipe wrench or similar tool to remove assembly from rod. Flaws in the rod surface may damage bearings and seal. Soft jaws in a vise are recommended to prevent diaphragm rod damage.

Step 1.A: NOTE: Not all inner diaphragm plates are threaded. Some models utilize a through hole in the inner diaphragm plate. If required to separate diaphragm assembly, place assembly in a vise, gripping on the exterior cast diameter of the inner plate. Turn the outer plate clockwise to separate the assembly.

Always inspect diaphragms for wear cracks or chemical attack. Inspect inner and outer plates for deformities, rust scale and wear. Inspect intermediate bearings for elongation and wear. Inspect diaphragm rod for wear or marks.

Clean or repair if appropriate. Replace as required.

Step 2: Reassembly: There are two different types of diaphragm plate assemblies utilized throughout the Sandpiper product line: Outer plate with a threaded stud, diaphragm, and a threaded inner plate.

Outer plate with a threaded stud, diaphragm, and an inner plate with through hole. Secure threaded inner plate in a vise. Ensure that the plates are being installed with the outer radius against the diaphragm.

Step 3: Lightly lubricate, with a compatible material, the inner faces of both outer and inner diaphragm plates when using on non Overlay diaphragms (For EPDM water is recommended). No lubrication is required.

Step 4: Push the threaded outer diaphragm plate through the center hole of the diaphragm.

Note: Most diaphragms are installed with the natural bulge out towards the fluid side. S05, S07, and S10 non-metallic units are installed with the natural bulge in towards the air side.

Step 5: Thread or place, outer plate stud into the inner plate. For threaded inner plates, use a torque wrench to tighten the assembly together. Torque values are called out on the exploded view.

Repeat procedure for second side assembly. Allow a minimum of 15 minutes to elapse after torquing, then re-torque the assembly to compensate for stress relaxation in the clamped assembly.

Step 6: Thread one assembly onto the diaphragm rod with sealing washer (when used) and bumper.

Step 7: Install diaphragm rod assembly into pump and secure by installing the outer chamber in place and tightening the capscrews.

Step 8: On opposite side of pump, thread the remaining assembly onto the diaphragm rod. Using a torque wrench, tighten the assembly to the diaphragm rod. Align diaphragm through bolt holes, always going forward past the recommended torque. Torque values are called out on the exploded view. **NEVER** reverse to align holes, if alignment cannot be achieved without damage to diaphragm, loosen complete assemblies, rotate diaphragm and reassemble as described above.

IMPORTANT



Read these instructions completely, before installation and start-up. It is the responsibility of the purchaser to retain this manual for reference. Failure to comply with the recommendations stated in this manual will damage the pump, and void factory warranty.

Warranty Information

5-YEAR *Limited Product Warranty*

Binks® manufacturing warrants to the original end-use purchaser that no product sold by Binks shall fail under normal use and service due to a defect in material or workmanship within five years from the date of shipment from Binks factory.

See complete warranty at www.binks.com

Contact Information

Binks Sales and Service: www.binks.com

For Models: 41-818820 and 41-818822

U.S.A./Canada Customer Service

195 Internationale Blvd
Glendale Heights, IL 60139

Tel. 630-237-5000

Fax 630-237-5011

**Toll Free Customer Service
and Technical Support**

800-992-4657

Toll Free Fax

888-246-5732

Binks European Sales and Service Listing: www.finishingbrands.eu

For Model: 41-818820-B and 41-818823-B

Binks has authorized distributors throughout the world. For technical assistance or the distributor nearest you, see listing below.

Finishing Brands (UK) Limited:

Ringwood Road, Bournemouth
Dorest BH11 9LH. UK

Tel. +44 (0) 1202 571 111

Fax +44 (0) 1202 573 488

General e-mail: info@finishingbrands.eu

Surfaces et Finitions:

163-171 Av. des Auréats
26014 Valence cedex. FR

Téléphone. +33 (0) 4 75 75 27 53

Télécopie +33 (0) 4 75 75 27 79

General e-mail: info@finishingbrands.eu

Finishing Brands Germany GmbH:

Justus-von-Liebig-Straße 31
63128 Dietzenbach. DE

Tel. +49 (0) 6074 403 1

Fax +49 (0) 607 403 300

General e-mail: info@finishingbrands.eu

BINKS[®]

GEMINI™ II SERIES

Declaration of Conformity

BINKS, 195 International Blvd, Glendale Heights, IL 60139

Certifies that BINKS models: 41-818810, 41-818810-B, 41-818820, 41-818820-B, 41-818822, 41-818830, 41-818830-B, 41-818831, 41-818831-B, 41-818823-B, 41-818836, 41-818836-B Air-Operated Double Diaphragm Pump comply with the European Community Directive 2006/42/EC on Machinery, according to Annex VIII. This product has used Harmonized Standard EN809:1998+A1:2009, Pumps and Pump Units for Liquids - Common Safety Requirements, to verify conformance.



Signature of authorized person

Charles W. McCulloch

Printed name of authorized person

Revision Level: F

June 8, 2012

Date of issue

Engineering Manager

Title

April 4, 2013

Date of revision



BINKS

GEMINI II SERIES

EC / EU Declaration of Conformity

The objective of the declaration described is in conformity
with the relevant Union harmonisation legislation:
Directive 94/9/EC (until April 19, 2016) and Directive 2014/34/EU (from April 20, 2016).

Manufacturer:

BINKS
196 International Blvd
Glendale Heights, IL 60139

Applicable Standard:

EN13463-1: 2009
EN13463-5: 2011



II 2 G c T5
II 2 D c T100°C

AODD Pumps (Air Operated Double Diaphragm Pumps)

Directive: 94/9/EC, Annex VIII

Technical File: 203104000-1410/MER

DEKRA Certification B.V. (0344)
Meander 1051
6825 MJ Arnhem
The Netherlands

DATE/APPROVAL/TITLE:

April 26, 2016

Charles W. McCulloch, Engineering Manager

Revision: A

Revision Date: April 26, 2016